

SUBMITTAL INFORMATION

METER SETTER 6020NL-3__H3H3-UUP

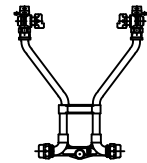

NO LEAD 3/4" FULL PORT METER BALL VALVE BY 3/4" FULL PORT METER BALL VALVE

CB COMPRESSION x CB COMPRESSION FOR COPPER OR PLASTIC TUBING (CTS)

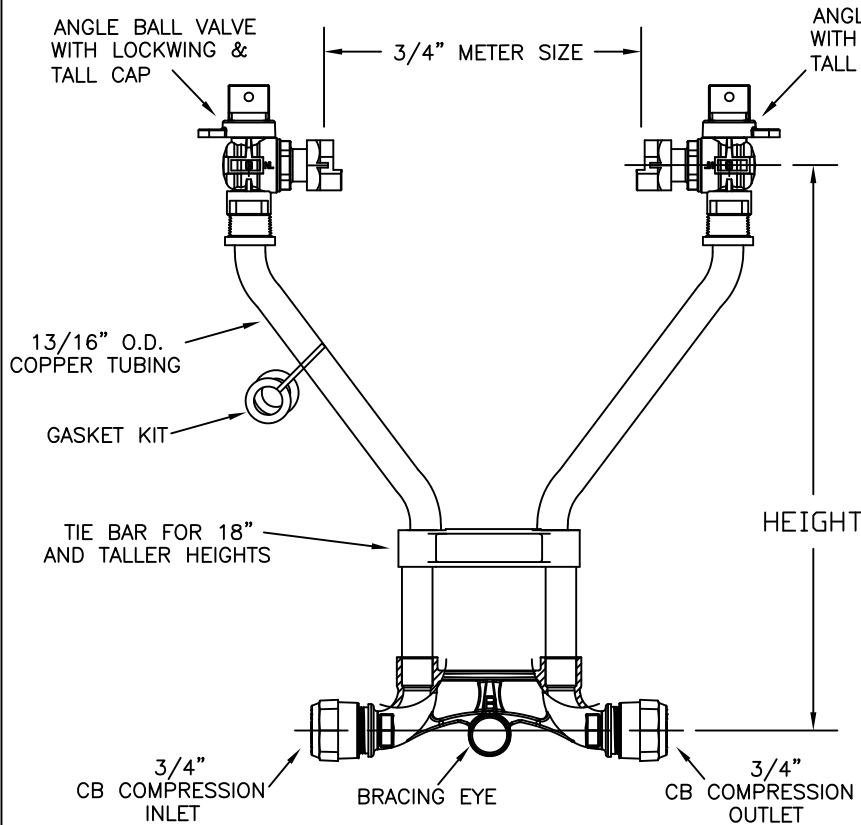

METER SETTER CATALOG NUMBERS

HEIGHT	CATALOG NUMBER	APPROX. WT. LBS.
7"	6020NL-307H3H3-UUP	
9"	6020NL-309H3H3-UUP	
12"	6020NL-312H3H3-UUP	
15"	6020NL-315H3H3-UUP	
18"	6020NL-318H3H3-UUP	
21"	6020NL-321H3H3-UUP	
24"	6020NL-324H3H3-UUP	
27"	6020NL-327H3H3-UUP	
30"	6020NL-330H3H3-UUP	

FEATURES:

- MANUFACTURED IN COMPLIANCE WITH AWWA STANDARD C800 (ASTM B-584, UNS NO C89833).
- CONFORMS TO ANSI/NSF 61-8
- CONFORMS TO ANSI/NSF 372 (COMPLIANT WITH US Safe Drinking Water Act. PL 111-380)
- CONSTRUCTED WITH TYPE K COPPER TUBING, ALLOY C12000 MANUFACTURED TO ASTM B88.
- SADDLE NUTS HOLD THE METER IN PLACE FOR TIGHTENING.
- TIE BAR IS STANDARD FOR 18" AND TALLER METER SETTER HEIGHTS.
- EPDM METER GASKETS PROVIDED
- 13/16" O.D. COPPER RISERS PROVIDE MORE FLOW CAPACITY.
- ANGLE VALVE HAS PADLOCK WINGS FOR LOCKING VALVE IN CLOSED POSITION.
- METER SETTER IS SHIPPED WITH PLASTIC METER IDLER
- ASSEMBLED WITH LEAD-FREE SOLDER.
- 180 DEG. FAHRENHEIT MAXIMUM CONSTANT TEMPERATURE.
- BRACING EYE IS STANDARD.

Cambridge Brass considers the information in this submittal form to be correct at the time of publication. Item and option availability, including specifications, are subject to change without notice.

Cambridge Brass
P.O. Box 249, 140 Orion Place
Cambridge, Ontario
Canada N1R 5V1
Tel: (519) 621-5520
Fax: (519) 621-8674
<http://www.cambridgebrass.com>

C CAMBRIDGE
BRASS

REV. A - JANUARY 2017
DWG. No. MSUB-67

SUBMITTED BY: