

Cambridge Brass
P.O. Box 249
140 Orion Place
Cambridge, Ontario
Canada N1R 5V1
Tel: (519) 621-5520
Fax: (519) 621-8674
http://www.cambridgebrass.com

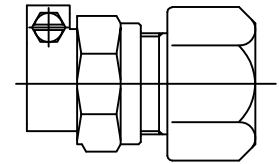

MODEL NO. 117NL

PJ CAMPAK X
FEMALE COPPER FLARE

ADAPTOR

FOR POLYETHYLENE PIPE, IPS-OD CONTROLLED, PER ASTM D3035 (PEP-SDR)
FOR PVC PIPE, IPS-OD CONTROLLED, PER ASTM D1785, ASTM D2241

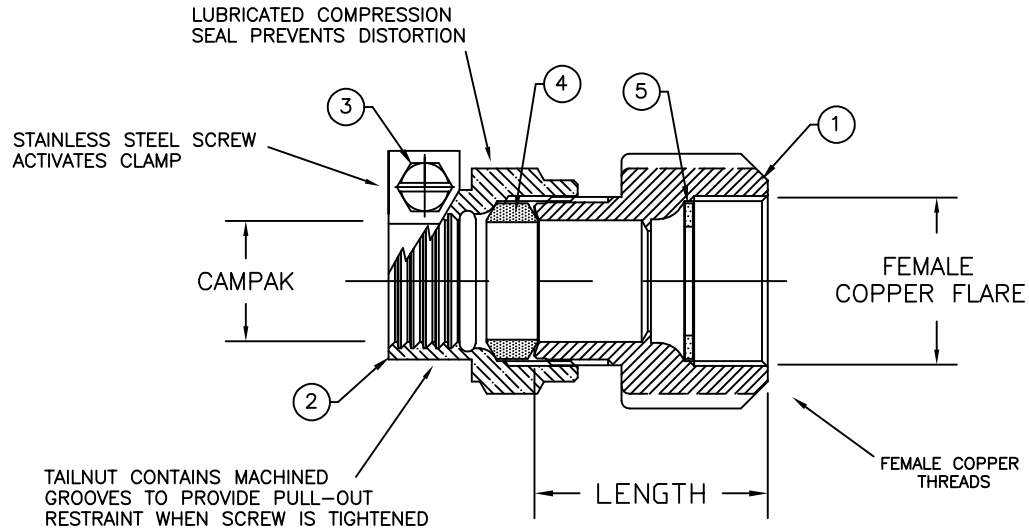

PARTS AND MATERIAL:

1. BODY: NO LEAD CAST BRASS, ALLOY C89833
2. COMPRESSION NUT: CAST BRASS, ALLOY C83600
3. SCREW: STAINLESS STEEL, ALLOY 304
4. COMPRESSION SEAL: NITRILE RUBBER
5. SEALING WASHER: COPPER

FEATURES:

- CONFORMS TO AWWA C800 (ASTM B584 UNS C89833 FOR ALL BRASS PARTS IN CONTACT WITH POTABLE WATER)
- CONFORMS TO ANSI/NSF 61-8
- CONFORMS TO ANSI/NSF 372 (COMPLIANT WITH US Safe Drinking Water Act. PL 111-380)
- BODY AND NUTS PROVIDE WRENCH FLATS FOR INSTALLATION
- 300PSI WORKING PRESSURE

Cambridge Brass considers the information in this submittal form to be correct at the time of publication. Item and option availability, including specifications, are subject to change without notice.

CATALOG NO.	CAMPAK	FEMALE COPPER FLARE	LENGTH	APPROX. WT. LBS.
117NL-PJ3P3	3/4"	3/4"	2.29"	1.0
117NL-PJ4P4	1"	1"	2.07"	1.0

Submitted by: