

# SUBMITTAL INFORMATION

METER SETTER 6020NL-2\_\_B3B3-V0



3/4" REDUCED PORT METER BALL VALVE BY METER SWIVEL NUT

CAMPAK x CAMPAK

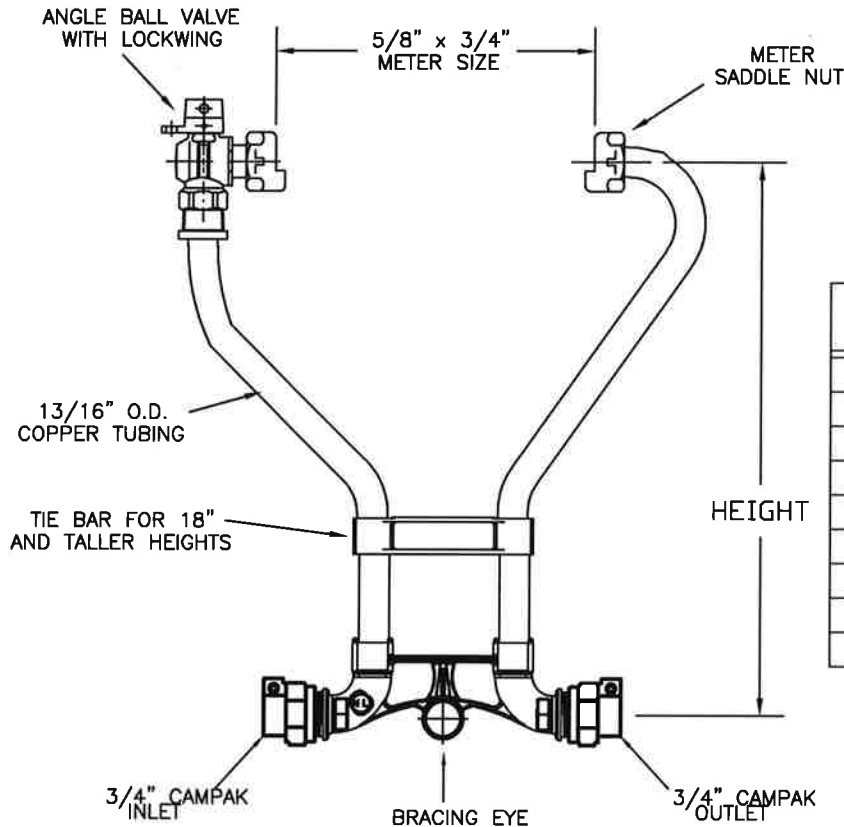

## METER SETTER CATALOG NUMBERS

| HEIGHT | CATALOG NUMBER    | APPROX. WT. LBS. |
|--------|-------------------|------------------|
| 7"     | 6020NL-207B3B3-V0 |                  |
| 9"     | 6020NL-209B3B3-V0 |                  |
| 12"    | 6020NL-212B3B3-V0 |                  |
| 15"    | 6020NL-215B3B3-V0 |                  |
| 18"    | 6020NL-218B3B3-V0 |                  |
| 21"    | 6020NL-221B3B3-V0 |                  |
| 24"    | 6020NL-224B3B3-V0 |                  |
| 27"    | 6020NL-227B3B3-V0 |                  |
| 30"    | 6020NL-230B3B3-V0 |                  |

### FEATURES:

- MANUFACTURED IN COMPLIANCE WITH AWWA STANDARD C800 (ASTM B-584, UNS NO C89833).
- CONFORMS TO ANSI/NSF 61-8
- CONFORMS TO ANSI/NSF 372 (COMPLIANT WITH US Safe Drinking Water Act. PL 111-380)
- SADDLE NUTS HOLD THE METER IN PLACE FOR TIGHTENING.
- TIE BAR IS STANDARD FOR 18" AND TALLER METER SETTER HEIGHTS.
- 13/16" O.D. COPPER RISERS PROVIDE MORE FLOW CAPACITY.
- ASSEMBLED WITH LEAD-FREE SOLDER.
- BRACING EYE IS STANDARD.

Cambridge Brass considers the information in this submittal form to be correct at the time of publication. Item and option availability, including specifications, are subject to change without notice.

Cambridge Brass  
 P.O. Box 249, 140 Orion Place  
 Cambridge, Ontario  
 Canada N1R 5V1  
 Tel: (519) 621-5520  
 Fax: (519) 621-8674  
<http://www.cambridgebrass.com>

**CAMBRIDGE  
 BRASS**

REV. A - JUNE 2022

SUBMITTED BY: