

SUBMITTAL INFORMATION

HORIZONTAL
SETTER

6020NL-7__H7H7-UUB

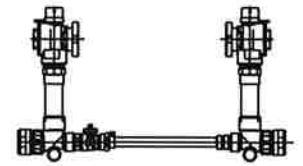

ANGLE BALL VALVE BY ANGLE BALL VALVE AT 2" METER

CB COMPRESSION INLET AND OUTLET

WITH 1" BYPASS

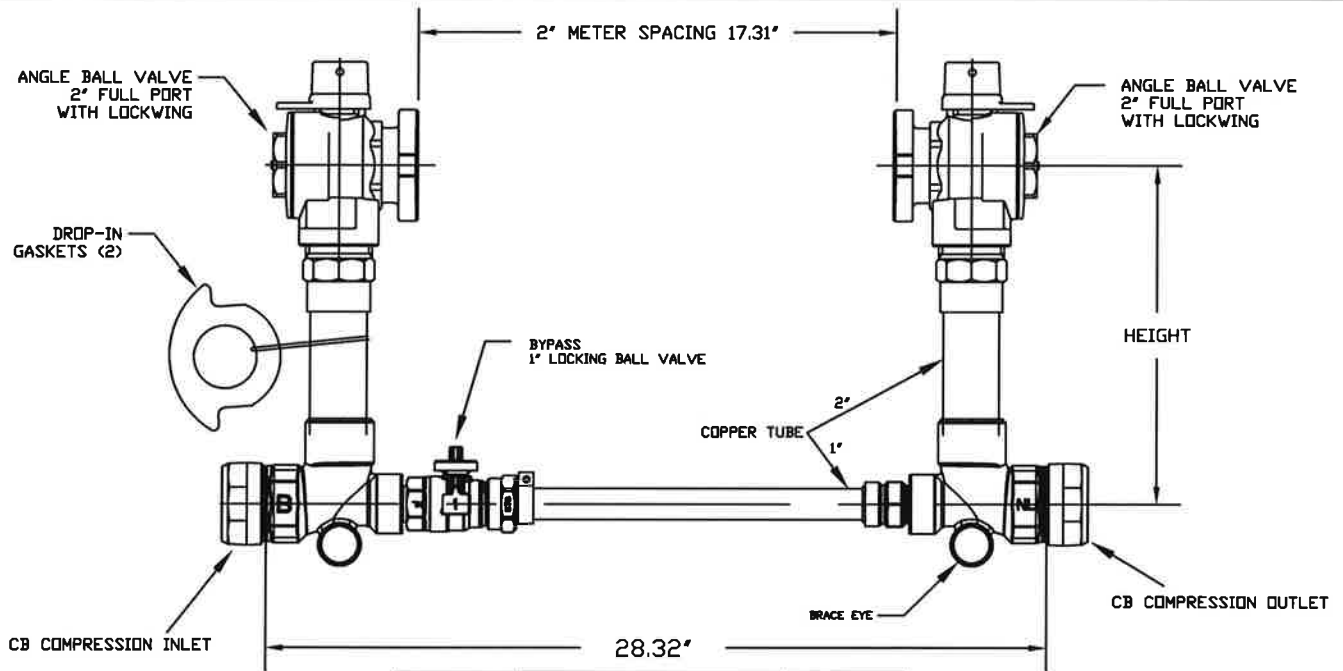

HEIGHT	CATALOG NUMBER	APPROX. WT. LBS.
12"	6020NL-712H7H7-UUB	
15"	6020NL-715H7H7-UUB	
18"	6020NL-718H7H7-UUB	
21"	6020NL-721H7H7-UUB	
24"	6020NL-724H7H7-UUB	
27"	6020NL-727H7H7-UUB	

FEATURES:

- MANUFACTURED IN COMPLIANCE WITH AWWA STANDARD C800 (ASTM B-584, UNS NO C89833 FOR BRASS PARTS IN CONTACT WITH POTABLE WATER, ASTM B-62 AND ASTM B-584, UNS NO C83600 FOR ALL OTHER BRASS PARTS).
- CONFORMS TO ANSI/NSF 61-8.
- CONFORMS TO ANSI/NSF 372 (COMPLIANT WITH US Safe Drinking Water Act. PL 111-380).
- ASSEMBLED WITH LEAD-FREE SOLDER.
- BRACING EYE IS STANDARD.
- POSITIONS THE METER DIRECTLY ABOVE THE CENTERLINE OF THE SERVICE.
- FURNISHED WITH TWO RUBBER GASKETS FOR METER NUTS/IDLER.
- CONSTRUCTED WITH TYPE K COPPER TUBING, ALLOY C1200 MANUFACTURED TO ASTM B88.
- ANGLE VALVE HAS PADLOCK WINGS FOR LOCKING VALVE IN CLOSED POSITION.
- FACTORY TESTED AT 90 PSI AIR PRESSURE UNDER WATER.
- 300 PSI WORKING PRESSURE.
- 180°F MAXIMUM CONSTANT TEMPERATURE.
- CHECK VALVE IS ASSE 1024 APPROVED.

Cambridge Brass considers the information in this submittal form to be correct at the time of publication. Item and option availability, including specifications, are subject to change without notice.

Cambridge Brass
P.O. Box 249, 140 Orion Place
Cambridge, Ontario
Canada N1R 5V1
Tel: (519) 621-5520
Fax: (519) 621-8674
<http://www.cambridgebrass.com>



SUBMITTED BY: