

SUBMITTAL INFORMATION

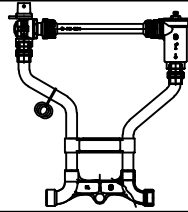

METER SETTER 6020NL-4__F4F4-UQP

1" FULL PORT METER BALL VALVE INLET AND DUAL CARTRIDGE CHECK VALVE OUTLET

1" FIP INLET AND 1" FIP OUTLET TO WATER SERVICE

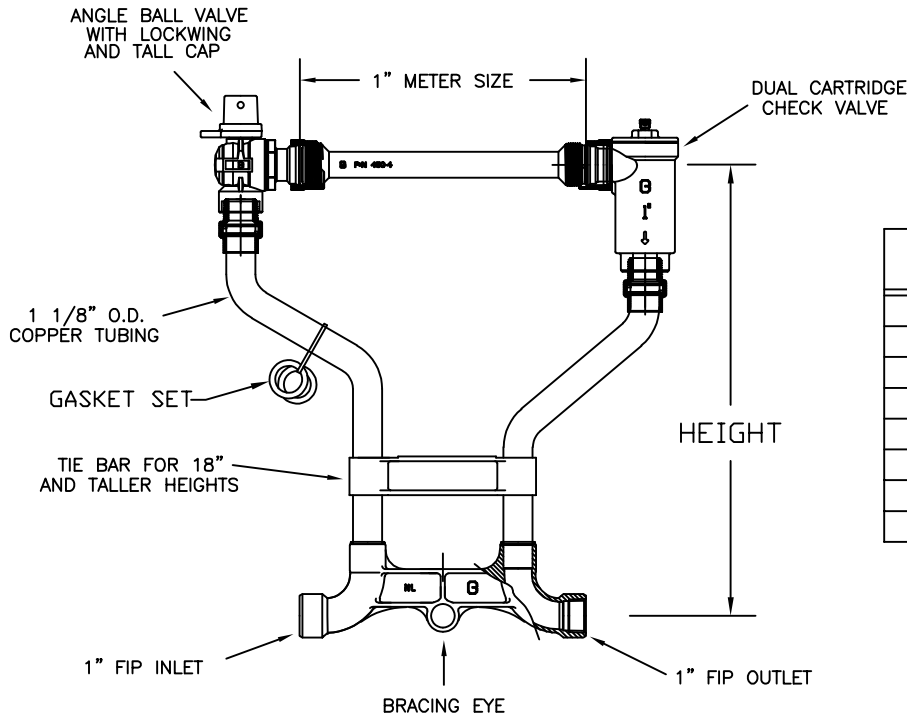

RESETTER CATALOG NUMBERS

HEIGHT	CATALOG NUMBER	APPROX. WT. LBS.
15"	6020NL-415F4F4-UQP	

FEATURES:

- ALL COMPONENTS CONFORM TO AWWA C800-05 (ASTM B-584, UNS NO C89833 FOR BRASS PARTS IN CONTACT WITH POTABLE WATER, AND ASTM B-62 AND B-584, UNS NO C83600 FOR ALL OTHER BRASS PARTS).
- SADDLE NUTS HOLD THE METER IN PLACE FOR TIGHTENING.
- TIE BAR IS STANDARD FOR 18" AND TALLER RESETTER HEIGHTS.
- 1 1/8" O.D. COPPER RISERS PROVIDE MORE FLOW CAPACITY.
- ASSEMBLED WITH LEAD-FREE SOLDER.
- BRACING EYE IS STANDARD.
- POSITIONS THE METER DIRECTLY ABOVE THE CENTERLINE OF THE SERVICE.
- FURNISHED WITH FOUR RUBBER GASKETS FOR METER NUTS AND BOTTOM BAR.
- CONSTRUCTED WITH TYPE K COPPER TUBING, ALLOY C12000 MANUFACTURED TO ASTM B88.
- ANGLE VALVE HAS PADLOCK WINGS FOR LOCKING VALVE IN CLOSED POSITION.
- METER SETTER IS SHIPPED WITH PLASTIC METER IDLER
- CONFORMS TO ANSI/NSF 372 (COMPLIANT WITH US Safe Drinking Water Act. PL 111-380)
- 180 DEG. FAHRENHEIT MAXIMUM CONSTANT TEMPERATURE.
- 175 PSI MAXIMUM WORKING PRESSURE.
- CHECK VALVE IS ASSE 1024 APPROVED

Cambridge Brass considers the information in this submittal form to be correct at the time of publication. Item and option availability, including specifications, are subject to change without notice.

Cambridge Brass
 P.O. Box 249, 140 Orion Place
 Cambridge, Ontario
 Canada N1R 5V1
 Tel: (519) 621-5520
 Fax: (519) 621-8674
<http://www.cambridgebrass.com>



REV. A - FEB 2021

SUBMITTED BY: