

Cambridge Brass
P.O. Box 249
140 Orion Place
Cambridge, Ontario
Canada N1R 5V1
Tel: (519) 621-5520
Fax: (519) 621-8674
http://www.cambridgebrass.com

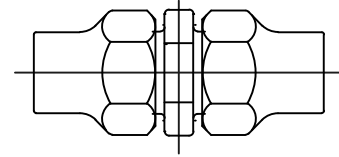

MODEL NO. 118NL

COPPER FLARE x COPPER FLARE

COUPLING

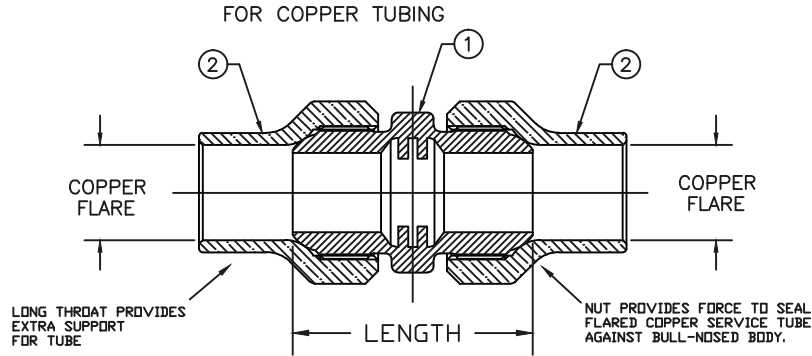

PARTS AND MATERIAL:
1. BODY: CAST BRASS, ALLOY C89833
2. COPPER FLARE NUT: CAST BRASS, ALLOY C83600

FEATURES:

- CONFORMS TO AWWA C800 (ASTM B584 UNS C89833 FOR ALL BRASS PARTS IN CONTACT WITH POTABLE WATER)
- CONFORMS TO ANSI/NSF 61-8
- CONFORMS TO ANSI/NSF 372 (COMPLIANT WITH US Safe Drinking Water Act. PL 111-380)
- BODY AND NUTS PROVIDE WRENCH FLATS FOR INSTALLATION
- 300PSI WORKING PRESSURE

ORDERING INFORMATION:
LESS NUT = ADD "LN" TO END OF CATALOG NO.

Cambridge Brass considers the information in this submittal form to be correct at the time of publication. Item and option availability, including specifications, are subject to change without notice.

CATALOG NO.	COPPER FLARE SIZE	COPPER FLARE SIZE	LENGTH	APPROX. WT. LBS.
118NL-C1C1	1/2"	1/2"	2.36"	0.8
118NL-C2C1	5/8"	1/2"	2.28"	0.9
118NL-C2C2	5/8"	5/8"	2.28"	1.2
118NL-C3C1	3/4"	1/2"	2.28"	1.1
118NL-C3C2	3/4"	5/8"	2.28"	1.1
118NL-C3C3	3/4"	3/4"	2.51"	1.2
118NL-C4C3	1"	3/4"	2.43"	1.6
118NL-C4C4	1"	1"	2.58"	1.9
118NL-C5C5	1 1/4"	1 1/4"	3.19"	3.8
118NL-C6C6	1 1/2"	1 1/2"	3.69"	5.1
118NL-C7C7	2"	2"	4.84"	8.5

Submitted by: