

Cambridge Brass  
P.O. Box 249  
140 Orion Place  
Cambridge, Ontario  
Canada N1R 5V1  
Tel: (519) 621-5520  
Fax: (519) 621-8674  
http://www.cambridgebrass.com

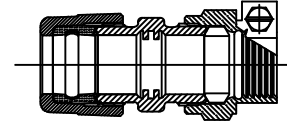

MODEL NO. 118NL

CB COMPRESSION x CAMPAK

COUPLING  
WITH INTERNAL STOPS

FOR COPPER OR PLASTIC TUBING (CTS)

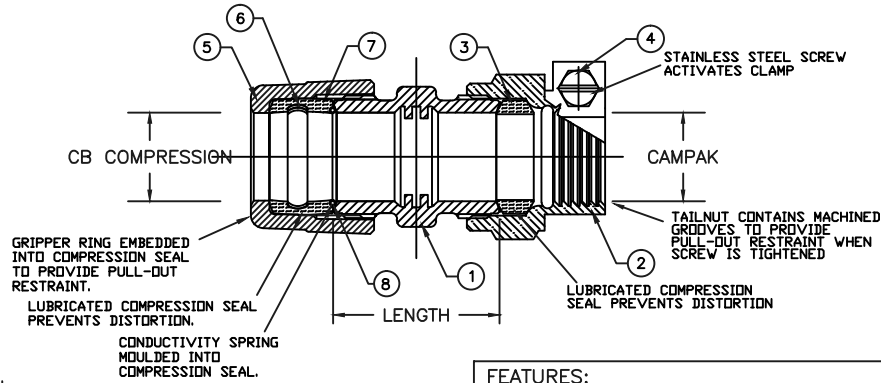

**PARTS AND MATERIAL:**

1. COUPLING BODY: NO LEAD CAST BRASS, ALLOY C89833
2. CAMPAK NUT: CAST BRASS, ALLOY C83600
3. COMPRESSION SEAL: NITRILE RUBBER
4. SCREW: STAINLESS STEEL, TYPE 304
5. COMPRESSION NUT: CAST BRASS, ALLOY C83600
6. GRIPPER: STAINLESS STEEL, TYPE 302
7. COMPRESSION SEAL: EPDM
8. CONDUCTOR SPRING: BRASS

**FEATURES:**

- CONFORMS TO AWWA C800 (ASTM B584 UNS C89833 FOR ALL BRASS PARTS IN CONTACT WITH POTABLE WATER)
- CONFORMS TO ANSI/NSF 61-8
- CONFORMS TO ANSI/NSF 372 (COMPLIANT WITH US Safe Drinking Water Act. PL 111-380)
- BODY AND NUTS PROVIDE WRENCH FLATS FOR INSTALLATION
- BODY PROVIDES INTERNAL TUBE STOPS.
- 300PSI WORKING PRESSURE

Cambridge Brass considers the information in this submittal form to be correct at the time of publication. Item and option availability, including specifications, are subject to change without notice.

CATALOG NO.	CB SIZE	CAMPAK SIZE	LENGTH	APPROX. WT. LBS.
118NL-H1B1	1/2"	1/2"	1.93"	1.0
118NL-H2B1	5/8"	1/2"	2.10"	1.0
118NL-H3B1	3/4"	1/2"	1.90"	1.0
118NL-H3B2	3/4"	5/8"	1.92"	1.0
118NL-H3B3	3/4"	3/4"	1.93"	1.0
118NL-H4B1	1"	1/2"	3.67"	2.4
118NL-H4B2	1"	5/8"	2.03"	1.2
118NL-H4B3	1"	3/4"	2.10"	1.4
118NL-H4B4	1"	1"	2.12"	1.5
118NL-H5B5	1 1/4"	1 1/4"	3.07"	2.1
118NL-H6B4	1 1/2"	1"	2.35"	2.1
118NL-H6B6	1 1/2"	1 1/2"	2.78"	3.7
118NL-H7B7	2"	2"	3.04"	5.3

Submitted by: