

Cambridge Brass  
P.O. Box 249  
140 Orion Place  
Cambridge, Ontario  
Canada N1R 5V1  
Tel: (519) 621-5520  
Fax: (519) 621-8674  
http://www.cambridgebrass.com

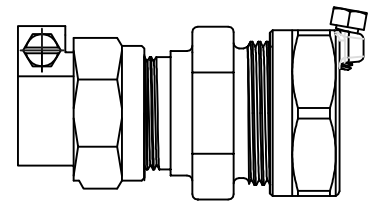

MODEL NO. 119NL

CAMPAK X IRON PIPE

COUPLING – FULL BORE

CAMPAK USES COPPER OR PLASTIC TUBING  
IRON PIPE USES GALVANIZED STEEL PIPE

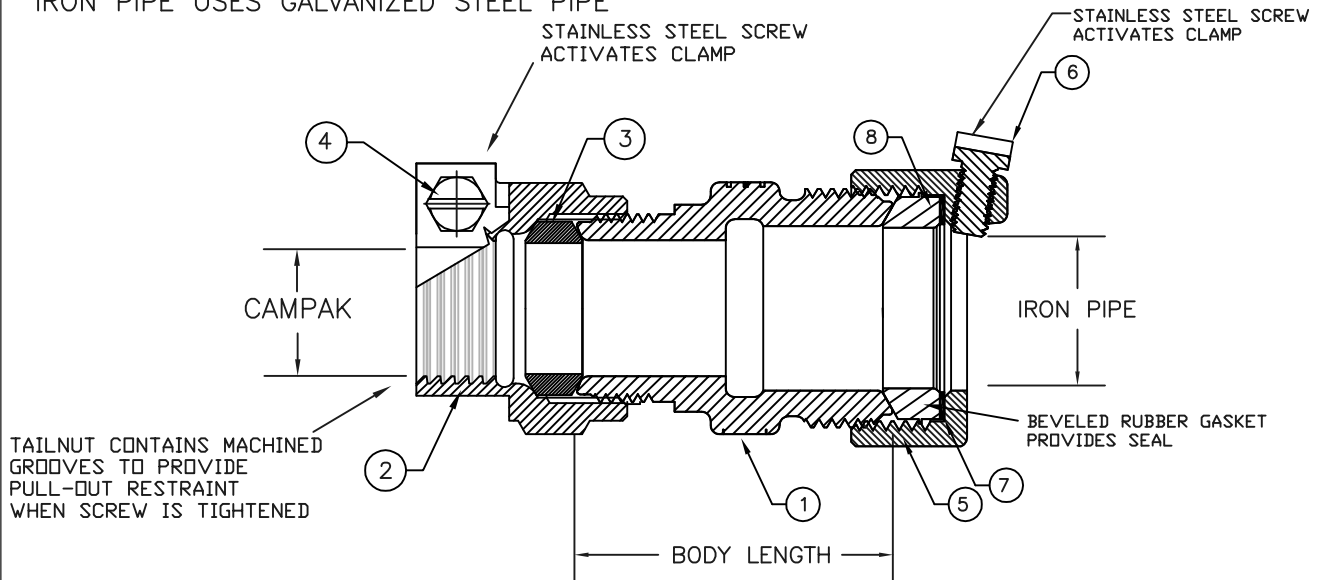

- PARTS AND MATERIAL:
1. COUPLING BODY: CAST BRASS, CDA ALLOY C89833
  2. CAMPAK NUT: CAST BRASS, ALLOY C83600
  3. COMPRESSION SEAL: NITRILE RUBBER
  4. SCREW: STAINLESS STEEL, TYPE 304
  5. IRON NUT: CAST BRASS, CDA ALLOY C83600
  6. SCREW: STAINLESS STEEL, ALLOY 304
  7. ANTI-FRICTION WASHER: HIGH DENSITY POLYETHYLENE (HDPE)
  8. GASKET: RUBBER COMPOUND NSF-61

FEATURES:

- CONFORMS TO AWWA C800 (ASTM B584 UNS C89833 FOR ALL BRASS PARTS IN CONTACT WITH POTABLE WATER)
- CONFORMS TO ANSI/NSF 61-8
- CONFORMS TO ANSI/NSF 372 (COMPLIANT WITH US Safe Drinking Water Act. PL111-380)
- BODY PROVIDES WRENCH FLATS FOR INSTALLATION
- 300 PSI WORKING PRESSURE

Cambridge Brass considers the information in this submittal form to be correct at the time of publication. Item and option availability, including specifications, are subject to change without notice.

| CATALOG NO. | CAMPAK | IP SIZE | BODY LENGTH | APPROX. WT. LBS. |
|-------------|--------|---------|-------------|------------------|
| 119NL-B1IP1 | 1/2"   | 1/2"    | 1.93"       |                  |
| 119NL-B1IP3 | 1/2"   | 3/4"    | 2.22"       |                  |
| 119NL-B3IP1 | 3/4"   | 1/2"    | 1.93"       |                  |
| 119NL-B3IP3 | 3/4"   | 3/4"    | 2.13"       |                  |
| 119NL-B3IP4 | 3/4"   | 1"      | 2.41"       |                  |
| 119NL-B4IP3 | 1"     | 3/4"    | 2.13"       |                  |
| 119NL-B4IP4 | 1"     | 1"      | 2.41"       |                  |

Submitted by: