

Cambridge Brass
P.O. Box 249
140 Orion Place
Cambridge, Ontario
Canada N1R 5V1
Tel: (519) 621-5520
Fax: (519) 621-8674
http://www.cambridgebrass.com

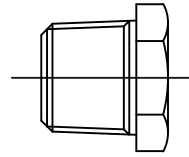

MODEL NO. 83NL

MALE IRON PIPE THREAD x
FEMALE AWWA TAPER THREAD

BRASS BUSHING
FOR CORPORATION STOPS

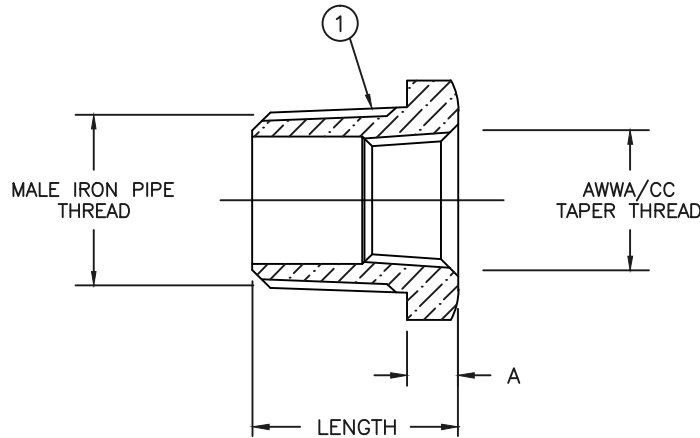

PARTS AND MATERIAL:
1. BUSHING: CAST BRASS, ALLOY C89833.

FEATURES:

- MANUFACTURED IN COMPLIANCE WITH AWWA STANDARD C800 (ASTM B-584, UNS NO C89833).
- CONFORMS TO AWWA C800 (ASTM B584 UNS C89833 FOR ALL BRASS PARTS IN CONTACT WITH POTABLE WATER)
- CONFORMS TO ANSI/NSF 61-8
- CONFORMS TO ANSI/NSF 372 (COMPLIANT WITH US Safe Drinking Water Act. PL 111-380)
- BODY PROVIDES WRENCH FLATES FOR PROPER INSTALLATION.
- 300 PSI WORKING PRESSURE

Cambridge Brass considers the information in this submittal form to be correct at the time of publication. Item and option availability, including specifications, are subject to change without notice.

CATALOG NO.	OUTSIDE THREAD SIZE	INSIDE THREAD SIZE	LENGTH	WRENCH FLAT HEIGHT (A)	APPROX. WT. LBS.
83NL-M4A3	1" MIP	3/4" AWWA	2.28"	1.00"	0.7
83NL-M6A3	1 1/2" MIP	3/4" AWWA	2.13"	.50"	1.2
83NL-M6A4	1 1/2" MIP	1" AWWA	2.13"	.50"	1.1
83NL-M7A3	2" MIP	3/4" AWWA	2.22"	.50"	1.1
83NL-M7A4	2" MIP	1" AWWA	2.22"	.50"	1.0
83NL-M7A6	2" MIP	1 1/2" AWWA	2.22"	.50"	

Submitted by: