

Cambridge Brass  
P.O. Box 249  
140 Orion Place  
Cambridge, Ontario  
Canada N1R 5V1  
Tel: (519) 621-5520  
Fax: (519) 621-8674  
http://www.cambridgebrass.com

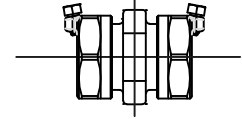

MODEL NO. 119NL

IRON PIPE x IRON PIPE

COUPLING – FULL BORE

FOR IRON PIPE X IRON PIPE

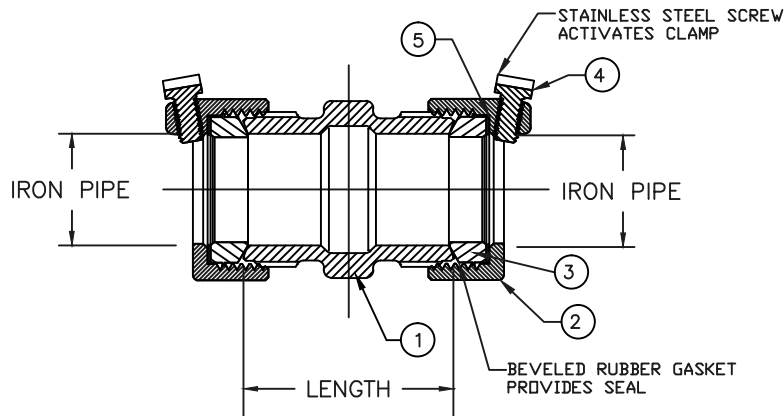

**PARTS AND MATERIAL:**

1. COUPLING BODY: NO LEAD CAST BRASS, ALLOY C89833
2. IRON PIPE NUT: CAST BRASS, ALLOY C83600
3. GASKET: RUBBER COMPOUND NSF-61
4. SCREW: STAINLESS STEEL, TYPE 304
5. ANTI-FRICTION WASHER: HDPE

**FEATURES:**

- MANUFACTURED IN COMPLIANCE WITH AWWA STANDARD C800-05 (ASTM B-62 AND ASTM B-584, UNS NO C83600-85-5-5-5).
- CONFORMS TO ANSI/NSF 61-8
- CONFORMS TO ANSI/NSF 372 (COMPLIANT WITH US Safe Drinking Water Act. PL 111-380)
- 300 PSI WORKING PRESSURE.
- BODY PROVIDES LARGE, RUGGED FLATS FOR PROPER INSTALLATION.

Cambridge Brass considers the information in this submittal form to be correct at the time of publication. Item and option availability, including specifications, are subject to change without notice.

CATALOG NO.	PEP SIZE	IRON PIPE SIZE	LENGTH	APPROX. WT. LBS.
119NL-IP1IP1	1/2"	1/2"	1.93"	
119NL-IP3IP3	3/4"	3/4"	2.12"	
119NL-IP3IP4	3/4"	1"	2.41"	
119NL-IP4IP3	1"	3/4"	2.41"	
119NL-IP4IP4	1"	1"	3.07"	

Submitted by: