

Cambridge Brass
P.O. Box 249
140 Orion Place
Cambridge, Ontario
Canada N1R 5V1
Tel: (519) 621-5520
Fax: (519) 621-8674
http://www.cambridgebrass.com

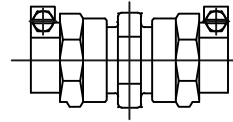

MODEL NO. 119NL

PVC COMPRESSION x
PVC COMPRESSION

COUPLING – FULL BORE

FOR PVC PIPE

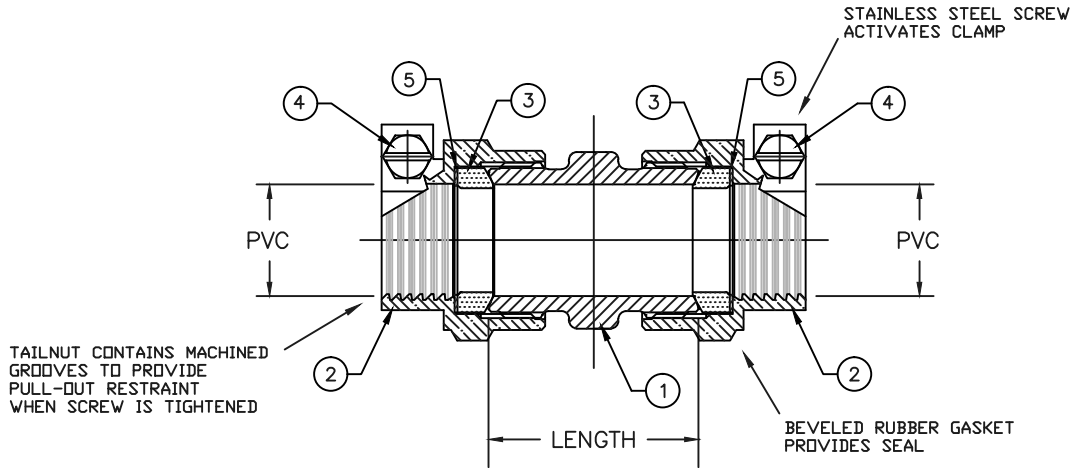

PARTS AND MATERIAL:

1. COUPLING BODY: CAST BRASS, ALLOY C89833
2. PVC NUT: CAST BRASS, ALLOY C83600
3. GASKET: RUBBER COMPOUND NSF-61
4. SCREW: STAINLESS STEEL, TYPE 304
5. ANTI-FRICTION WASHER: HDPE

FEATURES:

- CONFORMS TO AWWA C800 (ASTM B584 UNS C89833 FOR ALL BRASS PARTS IN CONTACT WITH POTABLE WATER)
- CONFORMS TO ANSI/NSF 61-8
- CONFORMS TO ANSI/NSF 372 (COMPLIANT WITH US Safe Drinking Water Act. PL111-380)
- BODY PROVIDES WRENCH FLATS FOR INSTALLATION
- 300 PSI WORKING PRESSURE

Cambridge Brass considers the information in this submittal form to be correct at the time of publication.
Item and option availability, including specifications, are subject to change without notice.

CATALOG NO.	PVC SIZE	PVC SIZE	LENGTH	APPROX. WT. LBS.
119NL-PJ3PJ3	3/4"	3/4"	2.12"	1.5
119NL-PJ4PJ4	1"	1"	3.07"	2.9
119NL-PJ6PJ6	1 1/2"	1 1/2"	3.04"	4.9
119NL-PJ7PJ7	2"	2"	3.37"	6.1

Submitted by: