

Cambridge Brass  
P.O. Box 249  
140 Orion Place  
Cambridge, Ontario  
Canada N1R 5V1  
Tel: (519) 621-5520  
Fax: (519) 621-8674  
http://www.cambridgebrass.com

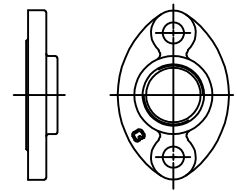

MODEL NO. 423NL

METER FLANGE x SOLDER JOINT

NO LEAD BRASS  
METER FLANGE KIT

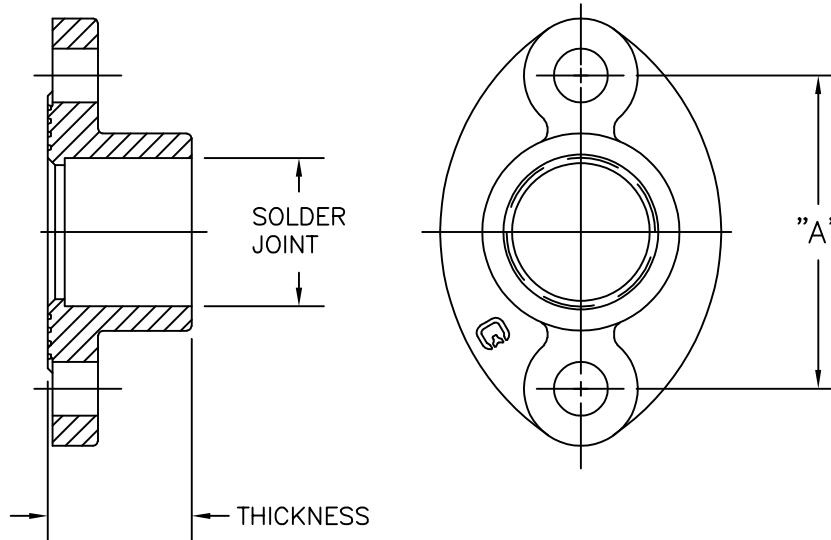

PARTS AND MATERIAL:  
FLANGE: CAST BRASS, ALLOY C89833  
BOLT: STAINLESS STEEL, 304  
NUT: STAINLESS STEEL, 304  
GASKET: EPDM

FEATURES:

- MANUFACTURED IN COMPLIANCE WITH AWWA STANDARD C800 (ASTM B-584, UNS NO C89833).
- INCLUDES 2-FLANGES, 2-GASKETS, 4-NUTS, 4-BOLTS.
- CONFORMS TO ANSI/NSF 61-8
- CONFORMS TO ANSI/NSF 372 (COMPLIANT WITH US Safe Drinking Water Act. PL 111-380)
- 300 PSI WORKING PRESSURE.

Cambridge Brass considers the information in this submittal form to be correct at the time of publication. Item and option availability, including specifications, are subject to change without notice.

| METER FLANGE SIZE | CATALOG NO. | SOLDER JOINT | THICKNESS | "A"    | BOLT HOLE DIAMETER | APPROX. WT. LBS. |
|-------------------|-------------|--------------|-----------|--------|--------------------|------------------|
| 1 1/2"            | 423NL-6SS   | 1 1/2"       | 1.50"     | 4"     | 11/16"             |                  |
| 2"                | 423NL-7SS   | 2"           | 1.63"     | 4 1/2" | 13/16"             |                  |

Submitted by: