

Cambridge Brass
P.O. Box 249
140 Orion Place
Cambridge, Ontario
Canada N1R 5V1
Tel: (519) 621-5520
Fax: (519) 621-8674
http://www.cambridgebrass.com

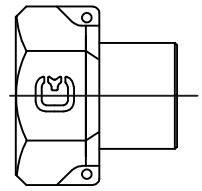

MODEL NO. 417NL

METER SWIVEL NUT x SOLDER JOINT

METER COUPLING

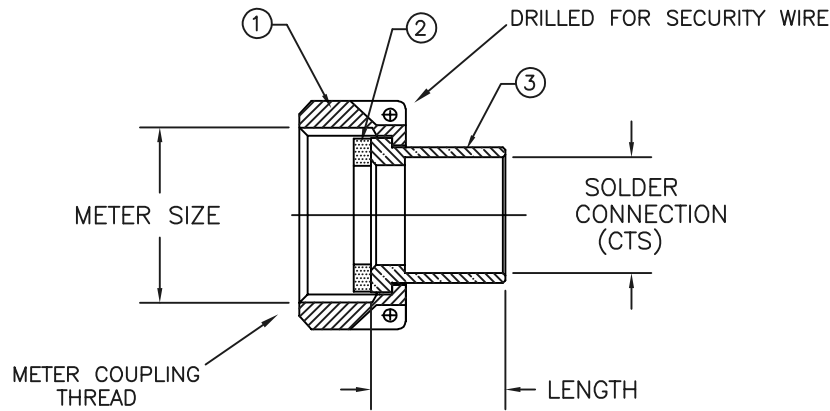

PARTS AND MATERIAL:

- 1. METER SWIVEL NUT: CAST BRASS, ALLOY C84400
- 2. GASKET: EPDM RUBBER
- 3. TAILPIECE: CAST BRASS, ALLOY C89833

FEATURES:

- ALL COMPONENTS CONFORM TO AWWA C800-05 (ASTM B-584, UNS NO C89833).
- CONFORMS TO AWWA C700 FOR METER THREADS.
- CONFORMS TO ANSI/NSF 61-8
- CONFORMS TO ANSI/NSF 372 (COMPLIANT WITH US Safe Drinking Water Act. PL 111-380)
- 300 PSI WORKING PRESSURE.

Cambridge Brass considers the information in this submittal form to be correct at the time of publication. Item and option availability, including specifications, are subject to change without notice.

CATALOG NO.	METER SIZE	METER THREAD	SOLDER CONNECTION	LENGTH	APPROX. WT. LBS.
417NL-T1S1	5/8"	3/4" NPSM	1/2" CTS	0.61"	
417NL-T1S3	5/8"	3/4" NPSM	1/2" CTS	1.85"	
417NL-T3S1	5/8"x3/4" & 3/4"	1" NPSM	3/4" CTS	0.98"	
417NL-T3S3	5/8"x3/4" & 3/4"	1" NPSM	3/4" CTS	1.02"	0.4
417NL-T4S4	1"	1 1/4" NPSM	1" CTS	1.18"	

Submitted by: