

Cambridge Brass
P.O. Box 249
140 Orion Place
Cambridge, Ontario
Canada N1R 5V1
Tel: (519) 621-5520
Fax: (519) 621-8674
http://www.cambridgebrass.com

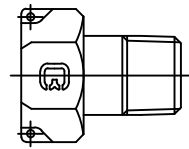

MODEL NO. 412NL

METER SWIVEL NUT x
MALE IRON PIPE

STRAIGHT METER COUPLING
INSIDE HEXAGON DRIVE

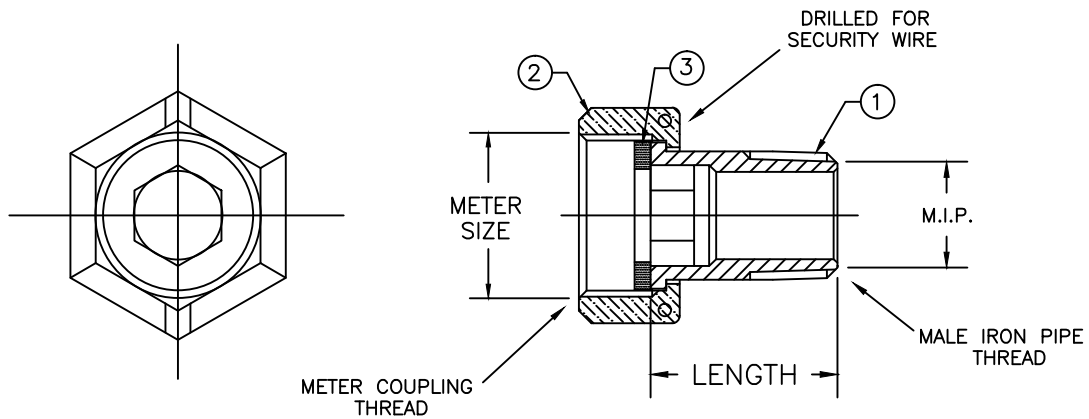

PARTS AND MATERIAL:

1. COUPLING BODY: CAST BRASS, ALLOY C89833
2. METER SWIVEL NUT: CAST BRASS, ALLOY C84400
3. METER GASKET: NEOPRENE

FEATURES:

- MANUFACTURED IN COMPLIANCE WITH AWWA STANDARD C800-05 (ASTM B-584, UNS NO C89833)
- SLIP-ON METER SWIVEL NUT
- CONFORMS TO AWWA C700 FOR METER THREADS.
- INSIDE WRENCH HEX.
- CONFORMS TO ANSI/NSF 61-8
- CONFORMS TO ANSI/NSF 372 (COMPLIANT WITH US Safe Drinking Water Act. PL 111-380)
- 300 PSI WORKING PRESSURE.

Cambridge Brass considers the information in this submittal form to be correct at the time of publication. Item and option availability, including specifications, are subject to change without notice.

CATALOG NO.	METER SIZE	METER THREAD	MALE IRON PIPE	LENGTH	APPROX. WT. LBS.
412NL-T3M3	5/8"X3/4" & 3/4"	1" NPSM	3/4"	1.50"	
412NL-T3M32500	5/8"X3/4" & 3/4"	1" NPSM	3/4"	2.50"	
412NL-T4M4	1"	1 1/4" NPSM	1"	1.50"	
412NL-T4M42500	1"	1 1/4" NPSM	1"	2.50"	

Submitted by: