

Cambridge Brass
P.O. Box 249
140 Orion Place
Cambridge, Ontario
Canada N1R 5V1
Tel: (519) 621-5520
Fax: (519) 621-8674
http://www.cambridgebrass.com

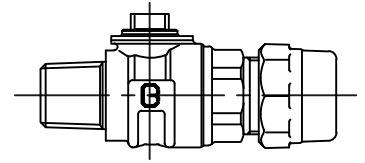

MODEL NO. 301NL

AWWA (CC) x CB COMPRESSION

CORPORATION MAIN STOP
BALL STYLE

AWWA/CC TAPER THREAD INLET BY CB COMPRESSION FOR COPPER OR PLASTIC TUBING (CTS) OUTLET

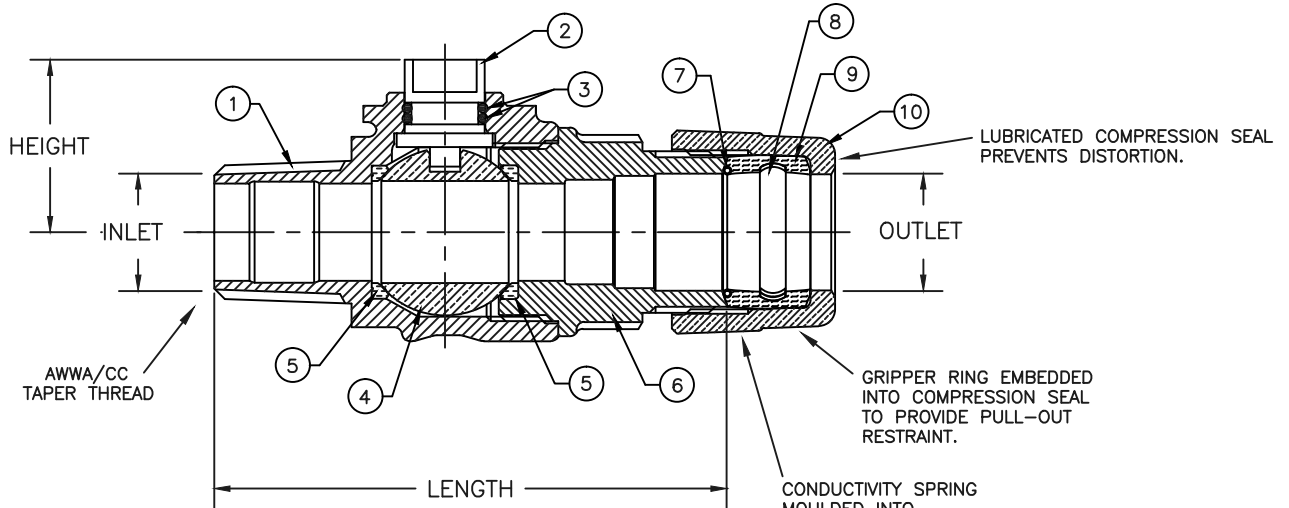

PARTS AND MATERIAL:

1. VALVE BODY: CAST BRASS, ALLOY C89833
2. STEM: STAINLESS STEEL, TYPE 303
3. O-RING: NITRILE RUBBER
4. BALL: CAST BRASS, ALLOY C89833
5. SEATS: TEFLON
6. ENDBODY: CAST BRASS, ALLOY C89833
7. CONDUCTOR SPRING: BRASS
8. GRIPPER: STAINLESS STEEL, TYPE 302
9. COMPRESSION SEAL: EPDM
10. TAILNUT: CAST BRASS, ALLOY C83600

FEATURES:

- ALL COMPONENTS CONFORM TO AWWA C800 (ASTM B-584, UNS NO C89833 FOR BRASS PARTS IN CONTACT WITH POTABLE WATER, AND ASTM B-62 AND B-584, UNS NO C83600 FOR ALL OTHER BRASS PARTS).
- CONFORMS TO ANSI/NSF 61-8
- CONFORMS TO ANSI/NSF 372 (COMPLIANT WITH US Safe Drinking Water Act. PL 111-380)
- BLOWOUT PROOF DESIGN.
- 300 PSI WORKING PRESSURE.
- BODY PROVIDES LARGE, RUGGED FLATS FOR PROPER INSTALLATION.
- FULL 360 DEGREE ROTATION.

Cambridge Brass considers the information in this submittal form to be correct at the time of publication. Item and option availability, including specifications, are subject to change without notice.

VALVE SIZE	CATALOG NO.	INLET AWWA/CC	OUTLET CB COMP.	LENGTH	HEIGHT	APPROX. WT. LBS.
5/8"	301NL-A2H2	5/8"	5/8"	3.92"	1.16"	1.5
3/4"	301NL-A3H3	3/4"	3/4"	4.05"	1.33"	1.8
3/4"	301NL-A3H4	3/4"	1"	4.30"	1.33"	2.1
1"	301NL-A4H4	1"	1"	4.59"	1.51"	2.8
1 1/4"	301NL-A5H5	1 1/4"	1 1/4"	6.37"	2.17"	8.2
1 1/2"	301NL-A6H6	1 1/2"	1 1/2"	6.49"	2.17"	7.5
1 1/2"	301NL-A6H7	1 1/2"	2"	6.53"	2.17"	8.2
2"	301NL-A7H7	2"	2"	6.78"	2.47"	10.6

Submitted by: