

Cambridge Brass
P.O. Box 249
140 Orion Place
Cambridge, Ontario
Canada N1R 5V1
Tel: (519) 621-5520
Fax: (519) 621-8674
http://www.cambridgebrass.com

SUBMITTAL
INFORMATION

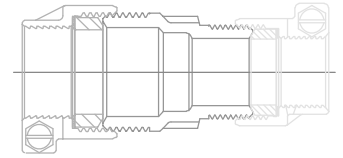

MODEL NO. 119NL

LEAD PIPE CAMPAK x
CTS CAMPAK

ADAPTOR

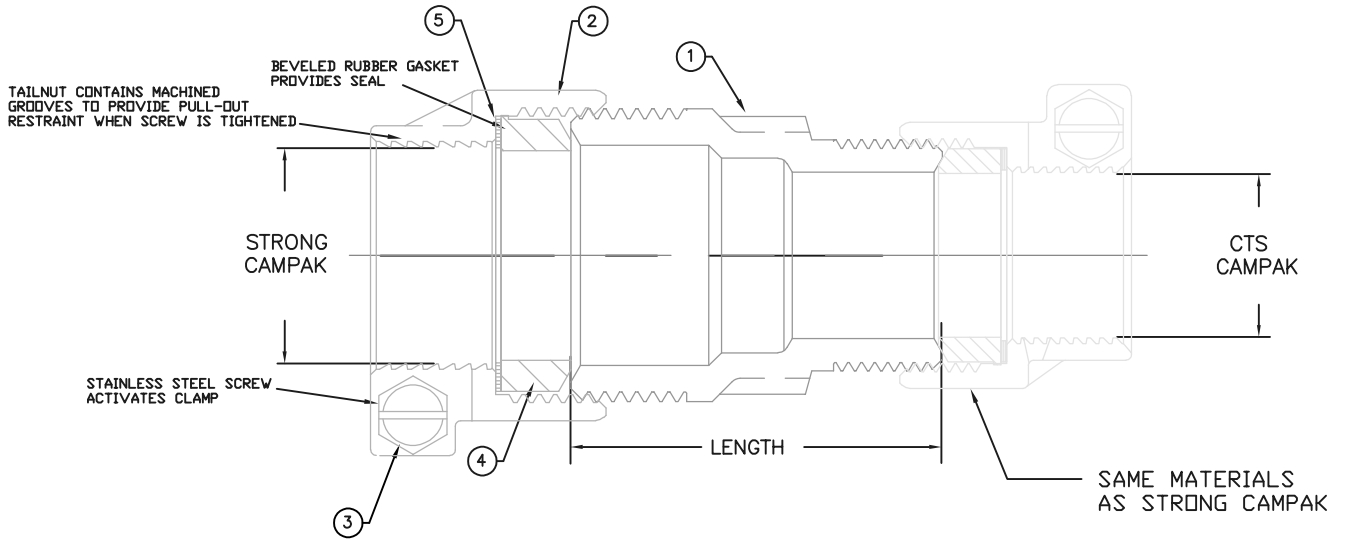

- PARTS AND MATERIAL:
1. BODY: CAST BRASS, ALLOY C89833
 2. PEP NUT: CAST BRASS, ALLOY C83600
 3. SCREW: STAINLESS STEEL, ALLOY 304
 4. GASKET: RUBBER COMPOUND NSF-61
 5. ANTI-FRICTION WASHER: HDPE

FEATURES:

- CONFORMS TO AWWA C800 (ASTM B584 UNS C89833 FOR ALL BRASS PARTS IN CONTACT WITH POTABLE WATER)
- CONFORMS TO ANSI/NSF 61-8
- CONFORMS TO ANSI/NSF 372 (COMPLIANT WITH US Safe Drinking Water Act. PL 111-380)
- BODY AND NUTS PROVIDE WRENCH FLATS FOR INSTALLATION
- 300PSI WORKING PRESSURE

Cambridge Brass considers the information in this submittal form to be correct at the time of publication. Item and option availability, including specifications, are subject to change without notice.

COUPLING SIZE	CATALOG NO.	LEAD PIPE CAMPAK	MALE IRON PIPE	LENGTH	
5/8" x 3/4"	119NL-X2B3	5/8"	3/4"	2.20"	
3/4"	119NL-X3B3	3/4"	3/4"	2.02"	
1"	119NL-X4B4	1"	1"	2.36"	

Submitted by: