

Cambridge Brass
P.O. Box 249
140 Orion Place
Cambridge, Ontario
Canada N1R 5V1
Tel: (519) 621-5520
Fax: (519) 621-8674
http://www.cambridgebrass.com

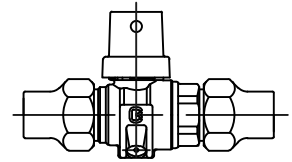

MODEL NO. 253NL

COPPER FLARE x COPPER FLARE

CURB STOP – BALL STYLE
DRAINING
OPEN RIGHT

FOR COPPER TUBING

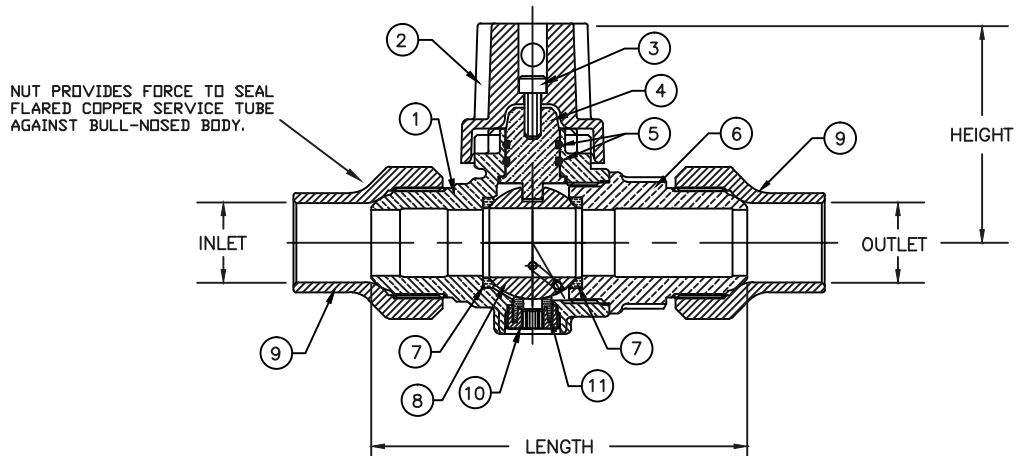

- PARTS AND MATERIAL:
1. VALVE BODY: CAST BRASS, ALLOY C89833
 2. CAP: CAST BRASS, ALLOY C83600
 3. CAP SCREW: STAINLESS STEEL, TYPE 304
 4. STEM: STAINLESS STEEL, TYPE 303
 5. O-RING: NITRILE RUBBER
 6. ENDBODY: CAST BRASS, ALLOY C89833
 7. SEATS: TEFLON
 8. BALL: CAST BRASS, ALLOY C89833
 9. TAILNUT: CAST BRASS, ALLOY C83600
 10. DRAIN PLUG: COPPER, ALLOY C36000
 11. DRAIN SEAL: NITRILE RUBBER

- FEATURES:
- MANUFACTURED IN COMPLIANCE WITH AWWA STANDARD C800 (ASTM B-584, UNS NO C89833 FOR BRASS PARTS IN CONTACT WITH POTABLE WATER, AND ASTM B-62 AND B-584 UNS NO C83600 FOR ALL OTHER BRASS PARTS).
 - CONFORMS TO ANSI/NSF 61-8
 - CONFORMS TO ANSI/NSF 372 (COMPLIANT WITH US Safe Drinking Water Act. PL 111-380)
 - BODY DESIGN INCLUDES HEAVY WRENCH FLATS FOR PROPER INSTALLATION.
 - ENCAPSULATED LUGS UNDER CAP PROVIDE 90 DEGREE OPEN TO CLOSE OPERATION.
 - HOLE FOR ATTACHING CURB BOX ROD OR HANDLE IS PROVIDED IN CAP.
 - BLOWOUT PROOF STEM DESIGN.
 - 300 PSI WORKING PRESSURE.
 - VALVES ARE DIRECTIONAL (FLOW DIRECTION ARROWS PROVIDED ON BODY).
 - VALVES HAVE "NL" CAST IN LETTERS FOR PROPER IDENTIFICATION.

ORDERING INFORMATION:
HANDLE = ADD "H" TO END OF CATALOG NO.

Cambridge Brass considers the information in this submittal form to be correct at the time of publication. Item and option availability, including specifications, are subject to change without notice.

VALVE SIZE	CATALOG NO.	INLET C.F.	OUTLET C.F.	LENGTH	HEIGHT	APPROX. WT. LBS.
3/4"	253NL-C3C3	3/4"	3/4"	4.29"	2.50"	2.3
1"	253NL-C4C4	1"	1"	4.80"	2.68"	3.9
1 1/2"	253NL-C6C6	1 1/2"	1 1/2"	7.56"	3.84"	12.1
2"	253NL-C7C7	2"	2"	8.16"	4.14"	18.3

Submitted by: