

Cambridge Brass
P.O. Box 249
140 Orion Place
Cambridge, Ontario
Canada N1R 5V1
Tel: (519) 621-5520
Fax: (519) 621-8674
http://www.cambridgebrass.com

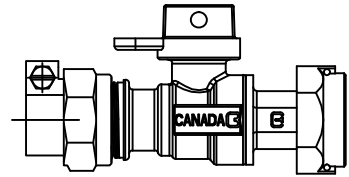

MODEL NO. 224NL

CAMPAK X
METER SWIVEL NUT

CURB STOP – BALL STYLE
REDUCED PORT WITH LOCKWING

FOR COPPER OR PLASTIC TUBING (CTS) x METER SPUD

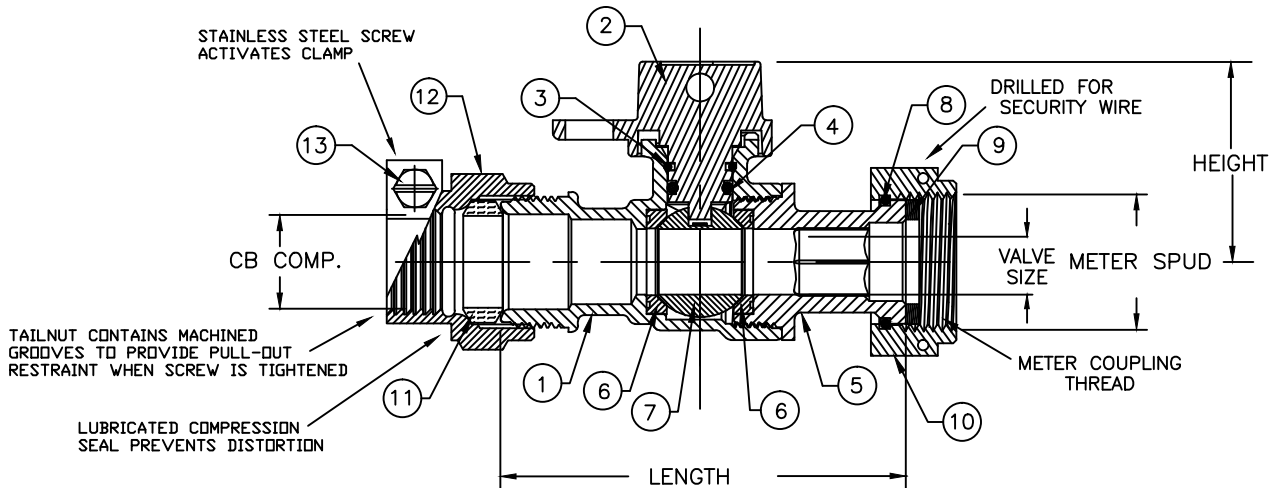

PARTS AND MATERIAL:

1. VALVE BODY: NO LEAD CAST BRASS, ALLOY C89833
2. CAP STEM S/A: NO LEAD CAST BRASS, ALLOY C89833
3. SNAP RING: PHOSPHOR BRONZE, ALLOY C51000
4. O-RING: NITRILE RUBBER
5. ENDBODY: NOM LEAD CAST BRASS, ALLOY C89833
6. SEATS: NITRILE RUBBER
7. BALL: COPPER, ALLOY C89833, TEFLON COATED
8. RETAINER RING: PHOSPHOR BRONZE WIRE
9. SEALING WASHER: NEOPRENE RUBBER
10. METER SWIVEL NUT: CAST BRASS, ALLOY C83600
11. COMPRESSION SEAL: NITRILE RUBBER
12. CAMPAK NUT: CAST BRASS, ALLOY C83600
13. SCREW: STAINLESS STEEL, ALLOY 304

FEATURES:

- CONFORMS TO AWWA C800 (ASTM B584 UNS C89833 FOR ALL BRASS PARTS IN CONTACT WITH POTABLE WATER)
- CONFORMS TO ANSI/NSF 61-8
- CONFORMS TO ANSI/NSF 372 (COMPLIANT WITH US Safe Drinking Water Act, PL 111-380)
- VALVES ARE NON-DIRECTION WHICH ALLOWS FLOW TO BE IN EITHER DIRECTION.
- BLOWOUT PROOF STEM DESIGN.
- 300 PSI WORKING PRESSURE.
- HOLE FOR ATTACHING CURB BOX ROD OR HANDLE IS PROVIDED IN CAP.
- PADLOCK WING FOR LOCKING VALVE IN CLOSED POSITION.
- METER THREADS CONFORM TO AWWA C700.
- ENCAPSULATED LUGS UNDER CAP PROVIDE 90 DEGREE OPEN TO CLOSE OPERATION.

ORDERING INFORMATION:
FULL 360 ROTATION = ADD "R" TO END OF CATALOG NO.
HANDLE = ADD "H" TO END OF CATALOG NO.

Cambridge Brass considers the information in this submittal form to be correct at the time of publication. Item and option availability, including specifications, are subject to change without notice.

VALVE SIZE	CATALOG NO.	CAMPAK	METER SIZE	LENGTH	HEIGHT	APPROX. WT. LBS.
5/8"	224NL-B3T3	3/4"	5/8"x3/4" & 3/4"	3.88"	1.93"	1.80

Submitted by: