

Cambridge Brass  
P.O. Box 249  
140 Orion Place  
Cambridge, Ontario  
Canada N1R 5V1  
Tel: (519) 621-5520  
Fax: (519) 621-8674  
http://www.cambridgebrass.com

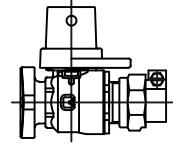

MODEL NO. 212NL

CAMPAK x METER FLANGE

STRAIGHT METER VALVE – BALL STYLE  
FULL PORT WITH LOCKWING

FOR COPPER OR PLASTIC TUBING (CTS) x METER FLANGE

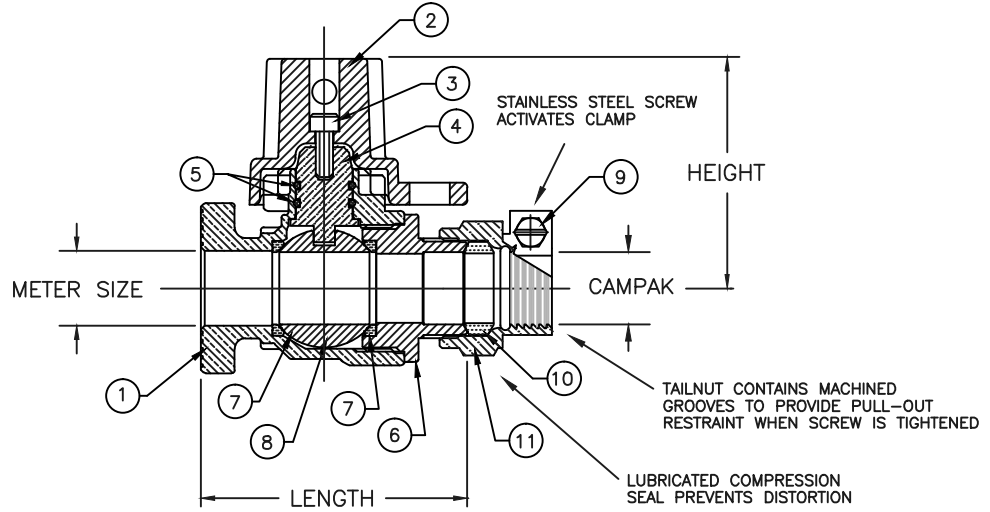

**PARTS AND MATERIAL:**

1. VALVE BODY: CAST BRASS, ALLOY C89833
2. CAP: CAST BRASS, ALLOY C83600
3. CAP SCREW: STAINLESS STEEL, TYPE 304
4. STEM: STAINLESS STEEL, TYPE 303
5. O-RING: NITRILE RUBBER
6. ENDBODY: CAST BRASS, ALLOY C89833
7. SEATS: TEFLON
8. BALL: CAST BRASS, ALLOY C89833
9. SCREW: STAINLESS STEEL, ALLOY 304
10. COMPRESSION SEAL: NITRILE RUBBER
11. CAMPAK TAILNUT: CAST BRASS, ALLOY C83600

**FEATURES:**

- MANUFACTURED IN COMPLIANCE WITH AWWA STANDARD C800 (ASTM B-584, UNS NO C89833).
- CONFORMS TO ANSI/NSF 61-8
- CONFORMS TO ANSI/NSF 372 (COMPLIANT WITH US Safe Drinking Water Act. PL 111-380)
- FLOW CAN BE IN EITHER DIRECTION.
- ROTATION STOPS RESISTS 200 FT-LB TORQUE.
- ENCAPSULATED LUGS UNDER CAP PROVIDE 90 DEGREE OPEN TO CLOSE OPERATION.
- BLOWOUT PROOF DESIGN.
- 300 PSI WORKING PRESSURE.
- HOLE FOR ATTACHING HANDLE IS PROVIDED IN CAP.
- PADLOCK WING FOR LOCKING VALVE IN CLOSED POSITION.
- SLOTTED HOLES ON 2" FLANGED METER VALVES ALLOWS 1 1/2" METER FLANGE CONNECTION.

**ORDERING INFORMATION:**

FULL 360 ROTATION = ADD "R" TO END OF CATALOG NO.  
HANDLE = ADD "H" TO END OF CATALOG NO.

Cambridge Brass considers the information in this submittal form to be correct at the time of publication. Item and option availability, including specifications, are subject to change without notice.

VALVE SIZE	CATALOG NO.	CAMPAK	METER SIZE	LENGTH	HEIGHT	APPROX. WT. LBS.
1 1/2"	212NL-B6MF6	1 1/2"	1 1/2"	6.09"	3.31"	
2"	212NL-B7MF7	2"	1 1/2" & 2"	6.43"	3.61"	

Submitted by: