

Cambridge Brass
P.O. Box 249
140 Orion Place
Cambridge, Ontario
Canada N1R 5V1
Tel: (519) 621-5520
Fax: (519) 621-8674
http://www.cambridgebrass.com

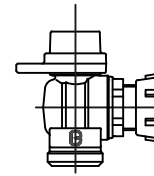

MODEL NO. 210NL

FEMALE IRON PIPE x
METER YOKE NOSE

ANGLE YOKE STYLE BALL VALVE
FULL PORT WITH LOCKWING

FOR THREADED PIPE x METER YOKE NOSE

PARTS AND MATERIAL:

1. VALVE BODY: CAST BRASS, ALLOY C89833
2. LOCKING CAP: CAST BRASS, ALLOY C83600
3. CAP SCREW: STAINLESS STEEL, TYPE 304
4. STEM: STAINLESS STEEL, TYPE 303
5. O-RING: NITRILE RUBBER
6. ENDBODY: CAST BRASS, ALLOY C89833
7. SEATS: TEFLON
8. BALL: CAST BRASS, ALLOY C89833
9. STAR NUT: CAST BRASS, ALLOY C83600

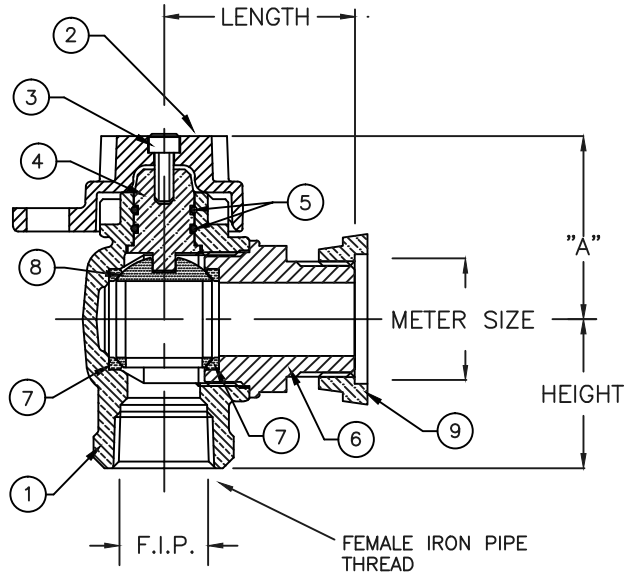

FEATURES:

- ALL COMPONENTS CONFORM TO AWWA C800-05 (ASTM B-584 UNS NO C89833 FOR BRASS PARTS IN CONTACT WITH POTABLE WATER, AND ASTM B-62 AND B-584 UNS NO C83600 FOR ALL OTHER BRASS PARTS).
- CONFORMS TO ANSI/NSF 61-8
- CONFORMS TO ANSI/NSF 372 (COMPLIANT WITH US Safe Drinking Water Act. PL 111-380)
- FLOW CAN BE IN EITHER DIRECTION.
- ROTATION STOPS RESISTS 200 FT-LB TORQUE.
- ENCAPSULATED LUGS UNDER CAP PROVIDE 90 DEGREE OPEN TO CLOSE OPERATION.
- BLOWOUT PROOF DESIGN.
- 300 PSI WORKING PRESSURE.
- HOLE FOR ATTACHING HANDLE IS PROVIDED IN CAP.
- PADLOCK WING FOR LOCKING VALVE IN CLOSED POSITION.

ORDERING INFORMATION:

FULL 360 ROTATION = ADD "R" TO END OF CATALOG NO.
HANDLE = ADD "H" TO END OF CATALOG NO. AND ADD 0.75" HEIGHT TO DIM. A
TALL CAP = ADD "P" TO END OF CATALOG NO. AND ADD 0.58" HEIGHT TO DIM. A

Cambridge Brass considers the information in this submittal form to be correct at the time of publication. Item and option availability, including specifications, are subject to change without notice.

VALVE SIZE	CATALOG NO.	F.I.P.	METER SIZE	HEIGHT	LENGTH	"A"	APPROX. WT. LBS.
3/4"	210NL-F3SR1	3/4"	5/8"	1.53"	2.25"	1.92"	
3/4"	210NL-F3SR3	3/4"	5/8"x3/4" & 3/4"	1.53"	2.25"	1.92"	1.91
1"	210NL-F4SR4	1"	1"	1.84"	2.53"	2.10"	
1"	210NL-F4SR3	1"	3/4"	1.84"	2.08"	2.10"	3.02

Submitted by: