

Cambridge Brass  
P.O. Box 249  
140 Orion Place  
Cambridge, Ontario  
Canada N1R 5V1  
Tel: (519) 621-5520  
Fax: (519) 621-8674  
http://www.cambridgebrass.com

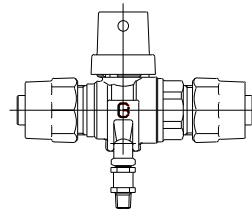

MODEL NO. 203NL

C903 x C903

CURB STOP – BALL STYLE  
WASTE DRAIN

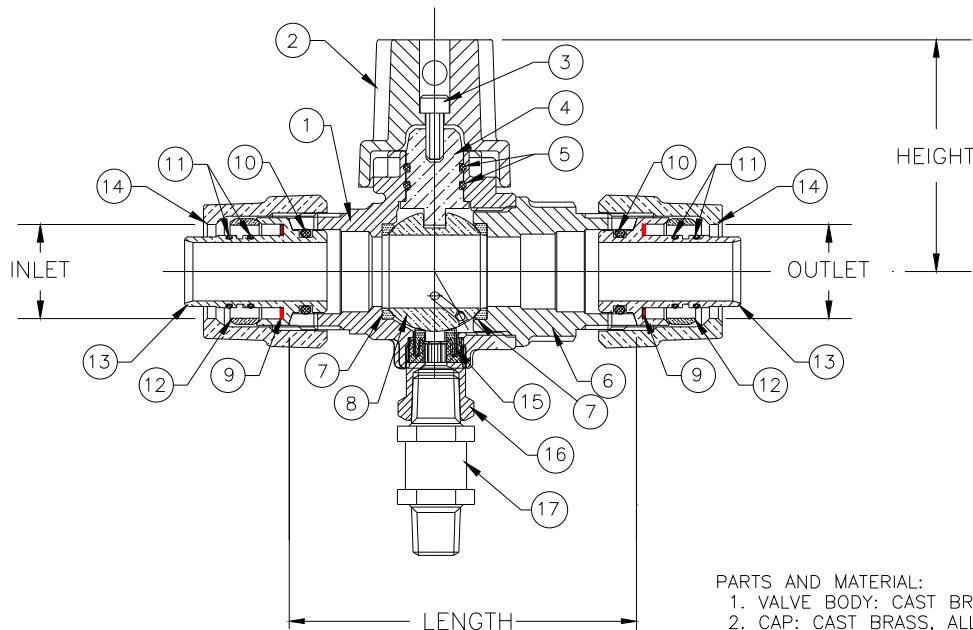

- PARTS AND MATERIAL:**
1. VALVE BODY: CAST BRASS, ALLOY C89833
  2. CAP: CAST BRASS, ALLOY C83600
  3. CAP SCREW: STAINLESS STEEL, TYPE 304
  4. STEM: STAINLESS STEEL, TYPE 303
  5. O-RING: NITRILE RUBBER
  6. ENDBODY: CAST BRASS, ALLOY C89833
  7. SEATS: TEFLON
  8. BALL: CAST BRASS, ALLOY C89833
  9. INSULATOR: POLYETHYLENE
  10. O-RING: NITRILE RUBBER
  11. O-RING: NITRILE RUBBER
  12. GRIPPER: BRASS, ALLOY C51000
  13. INSERT: CAST BRASS, ALLOY C89833
  14. C903 NUT: CAST BRASS, ALLOY C83600
  15. DRAIN SEAL: NITRILE RUBBER
  16. DRAIN PLUG: COPPER, ALLOY C36000
  17. CHECK VALVE: COPPER, ALLOY C36000

**FEATURES:**

- CONFORMS TO AWWA C800 (ASTM B584 UNS C89833 FOR ALL BRASS PARTS IN CONTACT WITH POTABLE WATER) AND ASTM B62 AND B-584 UNS NO C83600 FOR ALL OTHER BRASS PARTS).
- CONFORMS TO ANSI/NSF 61-8
- CONFORMS TO ANSI/NSF 372 (COMPLIANT WITH US Safe Drinking Water Act. PL 111-380)
- ROTATION STOPS RESISTS 200 FT-LB TORQUE.
- BLOWOUT PROOF DESIGN.
- ENCAPSULATED LUGS UNDER CAP PROVIDE 90 DEGREE OPEN TO CLOSE OPERATION.
- VALVES ARE DIRECTIONAL (FLOW DIRECTION ARROWS PROVIDED ON BODY).
- HOLE FOR ATTACHING CURB BOX ROD OR HANDLE IS PROVIDED IN CAP.
- 300 PSI WORKING PRESSURE.
- CHECK VALVE CRACKING PRESSURE 0.3 PSI.

**ORDERING INFORMATION:**  
FULL 360 ROTATION = ADD "R" TO END OF CATALOG NO.  
HANDLE = ADD "H" TO END OF CATALOG NO.

Cambridge Brass considers the information in this submittal form to be correct at the time of publication. Item and option availability, including specifications, are subject to change without notice.

VALVE SIZE	CATALOG NO.	INLET C903	OUTLET C903	LENGTH	HEIGHT	APPROX. WT. LBS.
3/4"	203NL-K3K3W	3/4"	3/4"	3.75"	2.50"	2.7
1"	203NL-K4K4W	1"	1"	4.42"	2.68"	4.2

Submitted by: