

Cambridge Brass
P.O. Box 249
140 Orion Place
Cambridge, Ontario
Canada N1R 5V1
Tel: (519) 621-5520
Fax: (519) 621-8674
http://www.cambridgebrass.com

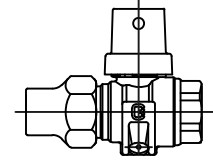

MODEL NO. 203NL

COPPER FLARE x FEMALE IRON PIPE

CURB STOP – BALL STYLE
DRAINING

FOR COPPER TUBING x THREADED PIPE

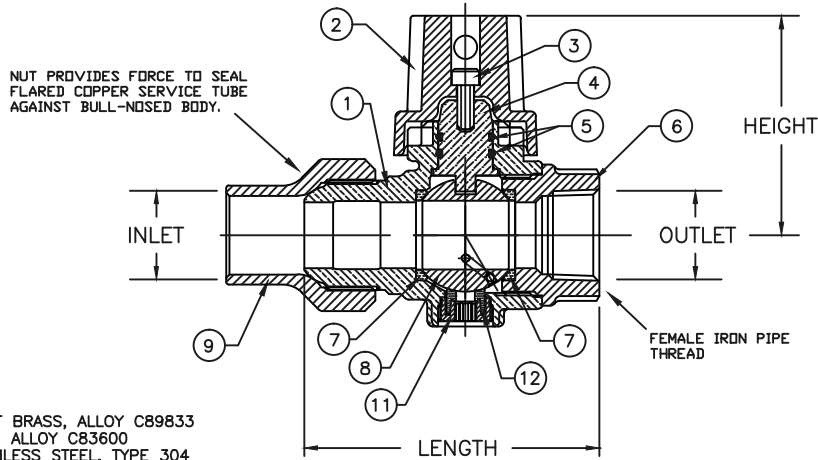

- PARTS AND MATERIAL:**
1. VALVE BODY: CAST BRASS, ALLOY C89833
 2. CAP: CAST BRASS, ALLOY C83600
 3. CAP SCREW: STAINLESS STEEL, TYPE 304
 4. STEM: STAINLESS STEEL, TYPE 303
 5. O-RING: NITRILE RUBBER
 6. ENDBODY: CAST BRASS, ALLOY C89833
 7. SEATS: TEFLON
 8. BALL: CAST BRASS, ALLOY C89833
 9. COPPER FLARE TAILNUT: CAST BRASS, ALLOY C83600
 10. ADAPTOR: CAST BRASS, ALLOY C89833
 11. DRAIN PLUG: COPPER, ALLOY C36000
 12. DRAIN SEAL: NITRILE RUBBER

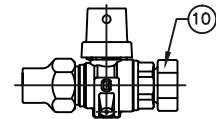

3/4" x 1/2" CONFIGURATION

- FEATURES:**
- CONFORMS TO AWWA C800 (ASTM B584 UNS C89833 FOR ALL BRASS PARTS IN CONTACT WITH POTABLE WATER)
 - CONFORMS TO ANSI/NSF 61-8
 - CONFORMS TO ANSI/NSF 372 (COMPLIANT WITH US Safe Drinking Water Act. PL 111-380)
 - ROTATION STOPS RESISTS 200 FT-LB TORQUE.
 - BLOWOUT PROOF DESIGN.
 - ENCAPSULATED LUGS UNDER CAP PROVIDE 90 DEGREE OPEN TO CLOSE OPERATION.
 - VALVES ARE DIRECTIONAL (FLOW DIRECTION ARROWS PROVIDED ON BODY).
 - HOLE FOR ATTACHING CURB BOX ROD OR HANDLE IS PROVIDED IN CAP.
 - 300 PSI WORKING PRESSURE.

ORDERING INFORMATION:
FULL 360 ROTATION = ADD "R" TO END OF CATALOG NO.
HANDLE = ADD "H" TO END OF CATALOG NO.

Cambridge Brass considers the information in this submittal form to be correct at the time of publication. Item and option availability, including specifications, are subject to change without notice.

VALVE SIZE	CATALOG NO.	INLET CF	OUTLET F.I.P.	LENGTH	HEIGHT	APPROX. WT. LBS.
3/4"	203NL-C3F1	3/4"	1/2"	4.49"	2.50"	
3/4"	203NL-C3F3	3/4"	3/4"	3.37"	2.50"	2.1
1"	203NL-C4F4	1"	1"	3.82"	2.68"	
1 1/4"	203NL-C5F5	1 1/4"	1 1/4"	5.59"	3.31"	
1 1/2"	203NL-C6F6	1 1/2"	1 1/2"	6.09"	3.84"	
2"	203NL-C7F7	2"	2"	6.56"	4.14"	

Submitted by: