

Cambridge Brass
P.O. Box 249
140 Orion Place
Cambridge, Ontario
Canada N1R 5V1
Tel: (519) 621-5520
Fax: (519) 621-8674
http://www.cambridgebrass.com

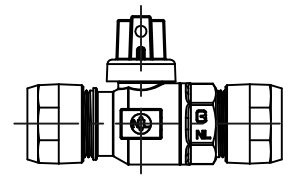

MODEL NO. 202NL

CB COMPRESSION x CB COMPRESSION

CURB STOP – BALL STYLE

FOR COPPER OR PLASTIC TUBING (CTS)

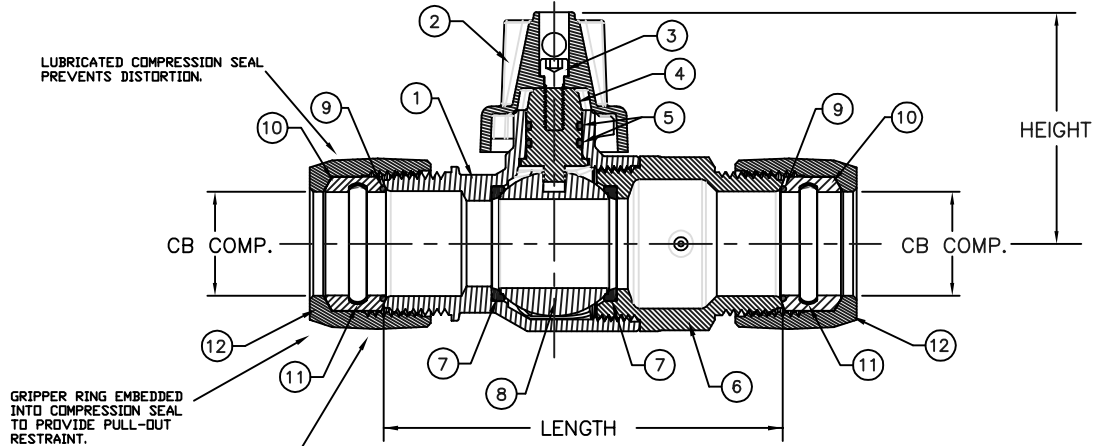

PARTS AND MATERIAL:

1. VALVE BODY: CAST BRASS, ALLOY C89833
2. CAP: CAST BRASS, ALLOY C83600
3. CAP SCREW: STAINLESS STEEL, TYPE 304
4. STEM: STAINLESS STEEL, TYPE 303
5. O-RING: NITRILE RUBBER
6. ENDBODY: CAST BRASS, ALLOY C89833
7. SEATS: TEFLON
8. BALL: CAST BRASS, ALLOY C89833
9. CONDUCTOR SPRING: BRASS
10. COMPRESSION SEAL: EPDM
11. GRIPPER: STAINLESS STEEL, TYPE 302
12. TAILNUT: CAST BRASS, ALLOY C83600

FEATURES

- CONFORMS TO AWWA C800 (ASTM B584 UNS C89833 FOR BRASS PARTS IN CONTACT WITH POTABLE WATER)
- CONFORMS TO ANSI/NSF 372 (COMPLIANT WITH US Safe Drinking Water Act. PL 111-380)
- CONFORMS TO ANSI/NSF 61-8
- BODY AND NUTS PROVIDE WRENCH FLATS FOR INSTALLATION
- 300PSI WORKING PRESSURE

ORDERING INFORMATION:

FULL 360 ROTATION = ADD "R" TO END OF CATALOG NO.
HANDLE = ADD "H" TO END OF CATALOG NO.

VALVE SIZE	CATALOG NO.	CB COMP.	CB COMP.	LENGTH	HEIGHT	APPROX. WT. LBS.
1/2"	202NL-H1H1	1/2"	1/2"	3.82"	1.90"	1.81
5/8"	202NL-H2H1	5/8"	1/2"	3.84"	1.90"	1.65
5/8"	202NL-H2H2	5/8"	5/8"	3.84"	1.90"	1.62
3/4"	202NL-H3H1	3/4"	1/2"	4.00"	1.90"	1.69
3/4"	202NL-H3H2	3/4"	5/8"	4.00"	1.90"	1.62
3/4"	202NL-H3H3	3/4"	3/4"	3.75"	2.50"	2.10
3/4"	202NL-H3H4	3/4"	1"	4.00"	2.50"	3.20
1"	202NL-H4H3	1"	3/4"	4.00"	2.50"	2.73
1"	202NL-H4H4	1"	1"	4.42"	2.68"	3.02
1 1/4"	202NL-H5H5	1 1/4"	1 1/4"	6.56"	3.31"	8.00
1 1/2"	202NL-H6H6	1 1/2"	1 1/2"	6.56"	3.31"	7.98
2"	202NL-H7H7	2"	2"	6.83"	3.61"	11.17