

Cambridge Brass
P.O. Box 249
140 Orion Place
Cambridge, Ontario
Canada N1R 5V1
Tel: (519) 621-5520
Fax: (519) 621-8674
http://www.cambridgebrass.com

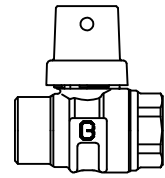

MODEL NO. 202NL

FEMALE IRON PIPE x FEMALE IRON PIPE

CURB STOP – BALL STYLE

FOR THREADED PIPE

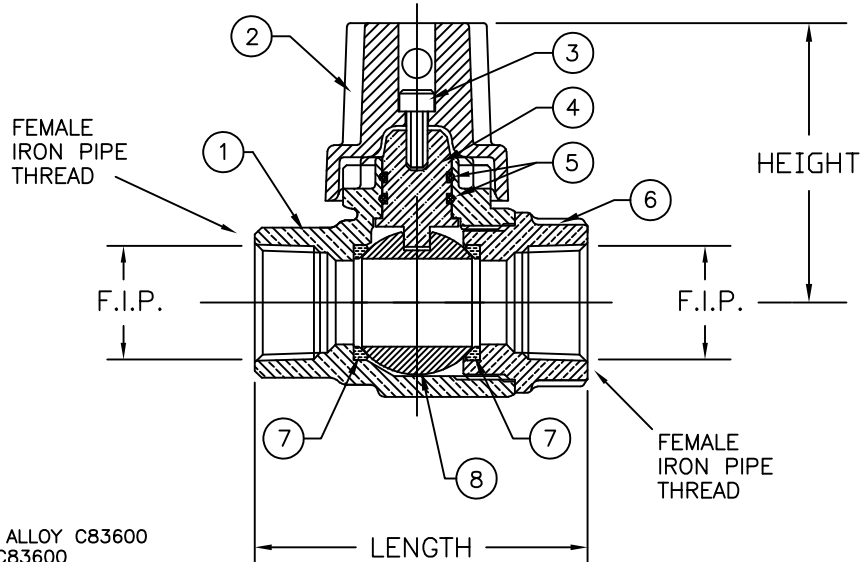

PARTS AND MATERIAL:

1. VALVE BODY: CAST BRASS, ALLOY C83600
2. CAP: CAST BRASS, ALLOY C83600
3. CAP SCREW: STAINLESS STEEL, TYPE 304
4. STEM: STAINLESS STEEL, TYPE 303
5. O-RING: NITRILE RUBBER
6. ENDBODY: CAST BRASS, ALLOY C83600
7. SEATS: TEFLON
8. BALL: CAST BRASS, ALLOY C89833

FEATURES:

- ALL COMPONENTS CONFORM TO AWWA STANDARD C800 (ASTM B-584 UNS NO C89833 FOR ALL BRASS PARTS IN CONTACT WITH POTABLE WATER, AND ASTM B-62 AND ASTM B-584 UNS NO C83600 FOR ALL OTHER BRASS PARTS).
- CONFORMS TO ANSI/NSF 372 (COMPLIANT WITH US Safe Drinking Water Act. PL 111-380)
- CONFORMS TO ANSI/NSF STANDARD 61-8.
- FLOW CAN BE IN EITHER DIRECTION.
- ROTATION STOPS RESISTS 200 FT-LB TORQUE.
- ENCAPSULATED LUGS UNDER CAP PROVIDE 90 DEGREE OPEN TO CLOSE OPERATION.
- HOLE FOR ATTACHING CURB BOX ROD OR HANDLE IS PROVIDED IN CAP.
- BLOWOUT PROOF DESIGN.
- 300 PSI WORKING PRESSURE.

ORDERING INFORMATION: FULL 360 ROTATION = ADD "R" TO END OF CATALOG NO.
HANDLE = ADD "H" TO END OF CATALOG NO.

Cambridge Brass considers the information in this submittal form to be correct at the time of publication. Item and option availability, including specifications, are subject to change without notice.

VALVE SIZE IN	CATALOG NO.	F.I.P. IN(mm)	F.I.P. IN(mm)	LENGTH IN(mm)	HEIGHT IN(mm)	APPROX. WT LBS.(kg)
3/4"	202NL-F3F3	3/4"(19)	3/4"(19)	2.98"(76)	2.50"(64)	1.8(0.82)
3/4"	202NL-F3F33437	3/4"(19)	3/4"(19)	3.437"(88)	2.50"(64)	2.0(0.91)
1"	202NL-F4F4	1"(25)	1"(25)	3.63"(92)	2.68"(68)	2.6(1.18)
1 1/4"	202NL-F5F5	1 1/4"(32)	1 1/4"(32)	4.84"(98)	3.31"(84)	6.8(3.08)
1 1/2"	202NL-F6F6	1 1/2"(38)	1 1/2"(38)	4.84"(98)	3.31"(84)	6.6(2.99)
2"	202NL-F7F7	2"(51)	2"(51)	5.21"(132)	3.61"(92)	9.2(4.17)

Submitted by: