

Cambridge Brass
P.O. Box 249
140 Orion Place
Cambridge, Ontario
Canada N1R 5V1
Tel: (519) 621-5520
Fax: (519) 621-8674
http://www.cambridgebrass.com

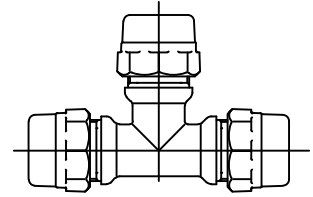

MODEL NO. 150NL

CB COMPRESSION x CB COMPRESSION
x CB COMPRESSION

SERVICE TEE

FOR COPPER OR PLASTIC (CTS) TUBING

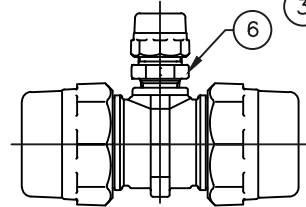
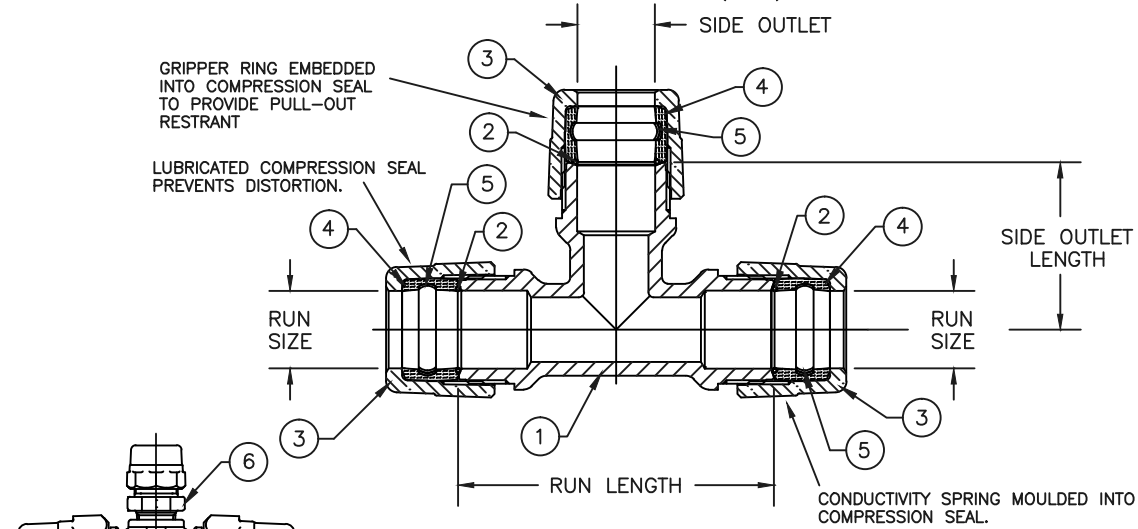

1 1/2" x 3/4" CONFIGURATION
2" x 3/4" CONFIGURATION
2" x 1" CONFIGURATION

PARTS AND MATERIAL:

1. TEE BODY: CAST BRASS, ALLOY C89833
2. CONDUCTOR SPRING: BRASS
3. COMPRESSION NUT: CAST BRASS, ALLOY C83600
4. COMPRESSION SEAL: EPDM
5. GRIPPER: STAINLESS STEEL, ALLOY 302
6. ADAPTOR: CAST BRASS, ALLOY C89833

FEATURES:

- CONFORMS TO AWWA C800 (ASTM B584 UNS C89833 FOR ALL BRASS PARTS IN CONTACT WITH POTABLE WATER)
- CONFORMS TO ANSI/NSF 61-8
- CONFORMS TO ANSI/NSF 372 (COMPLIANT WITH US Safe Drinking Water Act. PL 111-380)
- 300PSI WORKING PRESSURE

Cambridge Brass considers the information in this submittal form to be correct at the time of publication. Item and option availability, including specifications, are subject to change without notice.

TEE SIZE	CATALOG NO.	RUN CB COMP. (BOTH ENDS)	SIDE OUTLET CB COMP.	RUN LENGTH	SIDE OUTLET LENGTH	APPROX. WT. LBS.
3/4"	150NL-H3H3	3/4"	3/4"	3.66"	1.96"	1.9
3/4" x 1"	150NL-H3H4	3/4"	1"	3.66"	1.94"	2.3
1" x 3/4"	150NL-H4H3	1"	3/4"	5.10"	1.96"	2.3
1"	150NL-H4H4	1"	1"	5.10"	2.54"	3.6
1 1/2" x 3/4"	150NL-H6H3	1 1/2"	3/4"	3.40"	2.60"	4.0
1 1/2"	150NL-H6H6	1 1/2"	1 1/2"	4.75"	2.38"	4.4
2" x 3/4"	150NL-H7H3	2"	3/4"	4.15"	2.65"	5.2
2" x 1"	150NL-H7H4	2"	1"	4.15"	3.00"	5.6
2"	150NL-H7H7	2"	2"	7.38"	3.69"	6.9

Submitted by: