

Cambridge Brass
P.O. Box 249
140 Orion Place
Cambridge, Ontario
Canada N1R 5V1
Tel: (519) 621-5520
Fax: (519) 621-8674
http://www.cambridgebrass.com

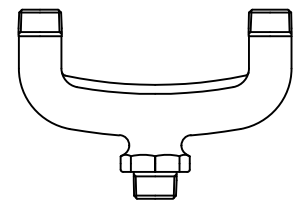

MODEL NO. 172NL

M.I.P. x M.I.P. x M.I.P.

NO LEAD U-BRANCH

MALE IRON PIPE INLET BY MALE IRON PIPE THREAD OUTLETS

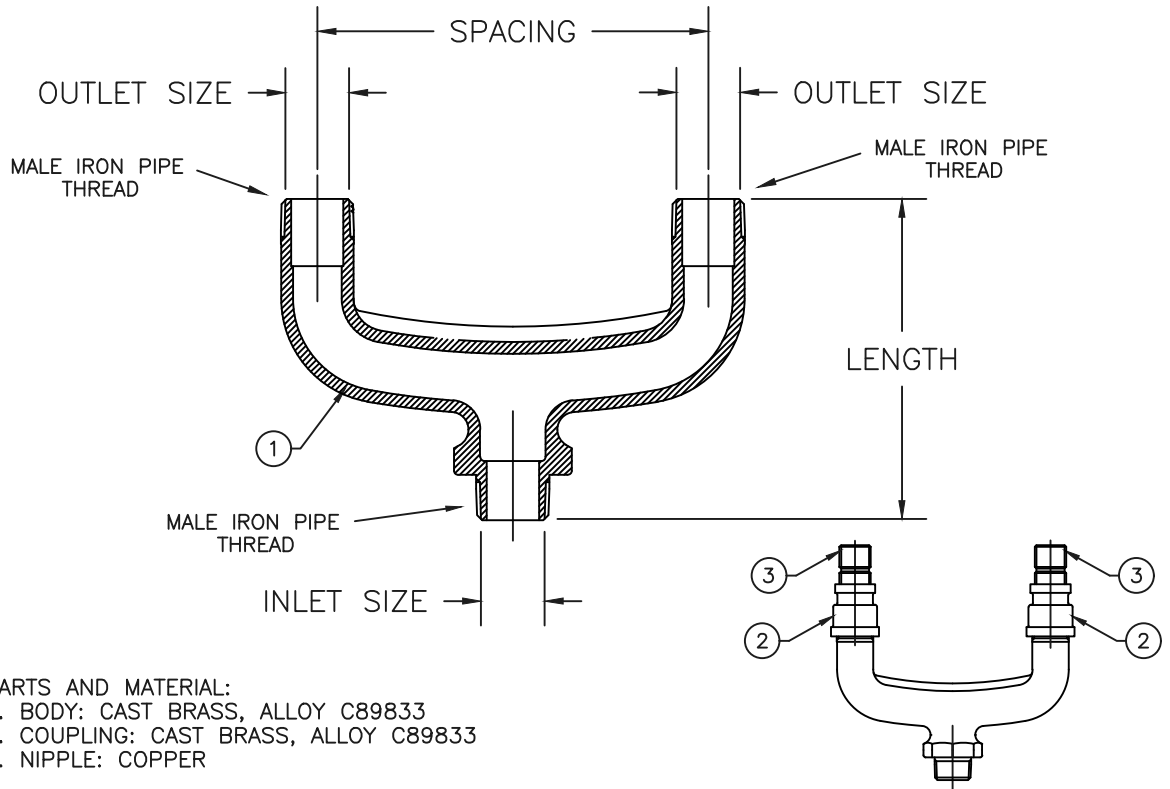

- PARTS AND MATERIAL:
1. BODY: CAST BRASS, ALLOY C89833
 2. COUPLING: CAST BRASS, ALLOY C89833
 3. NIPPLE: COPPER

172NL-M3M1 CONFIGURATION

FEATURES:

- ALL COMPONENTS CONFORM TO AWWA C800 (ASTM B-584, UNS NO C89833 FOR BRASS PARTS IN CONTACT WITH POTABLE WATER, AND ASTM B-62 AND B-584, UNS NO C83600 FOR ALL OTHER BRASS PARTS).
- CONFORMS TO ANSI/NSF 61-8
- CONFORMS TO ANSI/NSF 372 (COMPLIANT WITH US Safe Drinking Water Act. PL 111-380)
- BODY AND NUTS PROVIDE WRENCH FLATS FOR INSTALLATION
- 300PSI WORKING PRESSURE

Cambridge Brass considers the information in this submittal form to be correct at the time of publication. Item and option availability, including specifications, are subject to change without notice.

CATALOG NO.	INLET SIZE MALE IRON PIPE	OUTLET SIZE MALE IRON PIPE	SPACING	LENGTH	APPROX. WT. LBS.
172NL-M3M1	3/4"	1/2"	5.62"	5.25"	3.3
172NL-M3M3	3/4"	3/4"	5.62"	4.68"	1.8
172NL-M4M3	1"	3/4"	5.62"	4.85"	1.9
172NL-M4M37500	1"	3/4"	7.50"	3.88"	1.8

Submitted by: