

Cambridge Brass  
P.O. Box 249  
140 Orion Place  
Cambridge, Ontario  
Canada N1R 5V1  
Tel: (519) 621-5520  
Fax: (519) 621-8674  
http://www.cambridgebrass.com

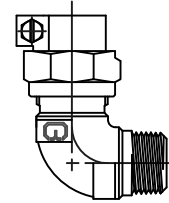

MODEL NO. 105NL

CAMPAK x MALE IRON PIPE

ELL COUPLING

CAMPAK COMPRESSION FOR COPPER OR PLASTIC TUBING (CTS) BY THREADED PIPE

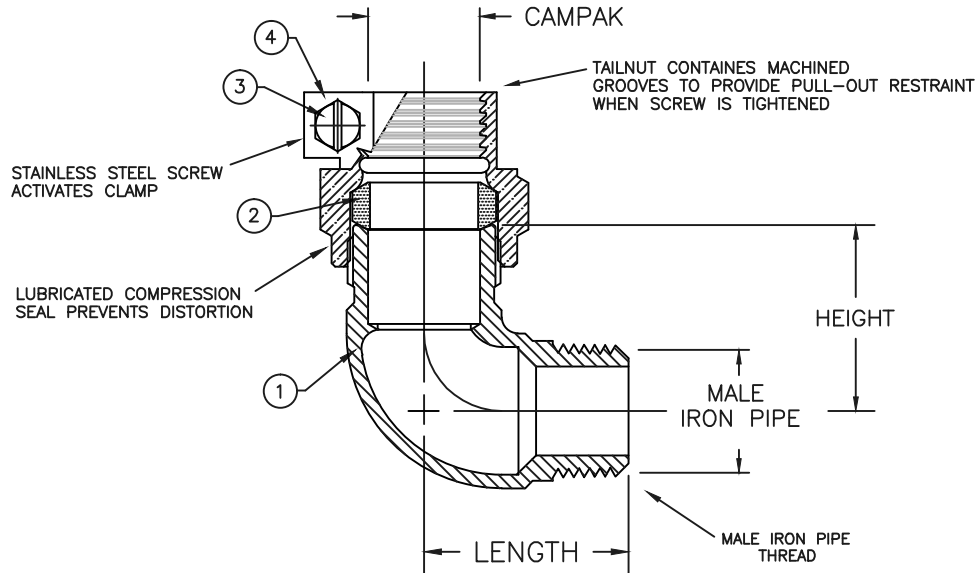

- PARTS AND MATERIAL:
1. ELBOW BODY: CAST BRASS, ALLOY C89833
  2. COMPRESSION SEAL: NITRILE RUBBER
  3. SCREW: STAINLESS STEEL, ALLOY 304
  4. CAMPAK NUT: CAST BRASS, ALLOY C83600

- FEATURES:
- ALL COMPONENTS CONFORM TO AWWA C800 (ASTM B-584 UNS NO C89833 FOR BRASS PARTS IN CONTACT WITH POTABLE WATER, AND ASTM B-62 AND B-584 UNS NO C83600 FOR ALL OTHER BRASS PARTS).
  - CONFORMS TO ANSI/NSF 61-8
  - CONFORMS TO ANSI/NSF 372 (COMPLIANT WITH US Safe Drinking Water Act. PL 111-380)
  - 300 PSI WORKING PRESSURE

Cambridge Brass considers the information in this submittal form to be correct at the time of publication. Item and option availability, including specifications, are subject to change without notice.

ELL COUPLING SIZE	CATALOG NO.	CAMPAK	MALE IRON PIPE	LENGTH	HEIGHT	APPROX. WT. LBS.
3/4"	105NL-B3M3	3/4"	3/4"	1.65"	1.50"	0.8
1"	105NL-B4M4	1"	1"	1.98"	1.79"	1.1
1 1/2"	105NL-B6M6	1 1/2"	1 1/2"	2.66"	2.54"	2.9
2"	105NL-B7M7	2"	2"	3.13"	3.14"	4.5

Submitted by: