

Cambridge Brass
P.O. Box 249
140 Orion Place
Cambridge, Ontario
Canada N1R 5V1
Tel: (519) 621-5520
Fax: (519) 621-8674
http://www.cambridgebrass.com

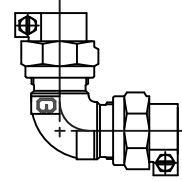

MODEL NO. 105NL

CAMPAK x CAMPAK

ELL COUPLING

CAMPAK COMPRESSION FOR COPPER OR PLASTIC TUBING (CTS)

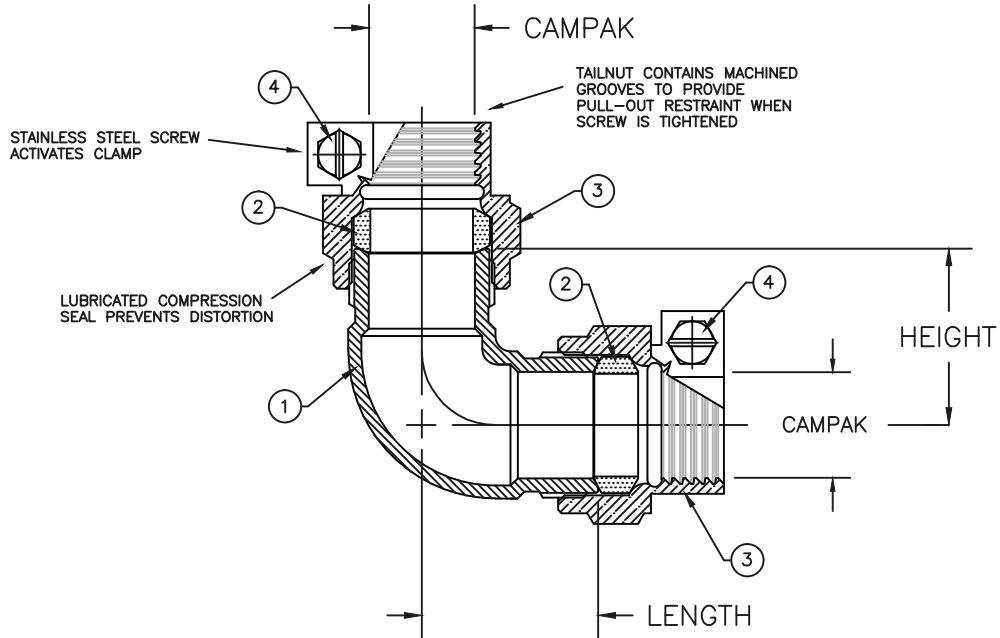

PARTS AND MATERIAL:

1. ELBOW BODY: CAST BRASS, ALLOY C89833
2. COMPRESSION SEAL: NITRILE RUBBER
3. CAMPAK NUT: CAST BRASS, ALLOY C83600
4. SCREW: STAINLESS STEEL, ALLOY 304

FEATURES:

- ALL COMPONENTS CONFORM TO AWWA C800 (ASTM B-584 UNS NO C89833 FOR BRASS PARTS IN CONTACT WITH POTABLE WATER, AND ASTM B-62 AND B-584 UNS NO C83600 FOR ALL OTHER BRASS PARTS).
- CONFORMS TO ANSI/NSF 61-8
- CONFORMS TO ANSI/NSF 372 (COMPLIANT WITH US Safe Drinking Water Act. PL 111-380)
- 300 PSI WORKING PRESSURE

Cambridge Brass considers the information in this submittal form to be correct at the time of publication. Item and option availability, including specifications, are subject to change without notice.

ELL COUPLING SIZE	CATALOG NO.	CAMPAK BOTH ENDS	LENGTH	HEIGHT	APPROX. WT. LBS.
3/4"	105NL-B3B3	3/4"	1.50"	1.50"	1.1
1"	105NL-B4B4	1"	1.79"	1.79"	1.8
1 1/2"	105NL-B6B6	1 1/2"	2.60"	2.60"	5.0
2"	105NL-B7B7	2"	3.14"	3.14"	7.5

Submitted by: