

Cambridge Brass
P.O. Box 249
140 Orion Place
Cambridge, Ontario
Canada N1R 5V1
Tel: (519) 621-5520
Fax: (519) 621-8674
http://www.cambridgebrass.com

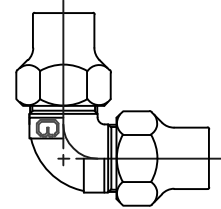

MODEL NO.105NL

COPPER FLARE x COPPER FLARE

ELL COUPLING
NO LEAD

COPPER FLARE BY COPPER FLARE FOR COPPER SERVICE TUBING

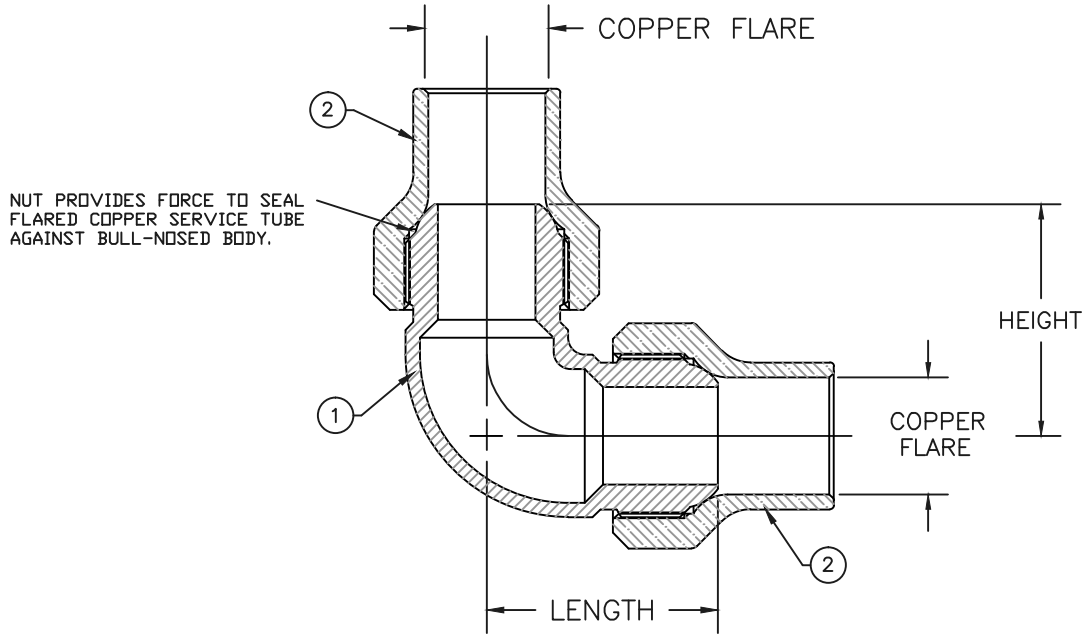

PARTS AND MATERIAL:

- 1. ELBOW BODY - CAST BRASS, NO LEAD ALLOY C89833
- 2. NUT - CAST BRASS, ALLOY C83600

FEATURES:

- ALL COMPONENTS CONFORM TO AWWA C800-05 (ASTM B-584 UNS NO C89833 FOR BRASS PARTS IN CONTACT WITH POTABLE WATER, AND ASTM B-62 AND B-584 UNS NO C83600 FOR ALL OTHER BRASS PARTS).
- CONFORMS TO ANSI/NSF 61-8
- CONFORMS TO ANSI/NSF 372 (COMPLIANT WITH US Safe Drinking Water Act. PL 111-380)
- 300 PSI WORKING PRESSURE
- BODY PROVIDES WRENCH FLATES FOR PROPER INSTALLATION.

Cambridge Brass considers the information in this submittal form to be correct at the time of publication. Item and option availability, including specifications, are subject to change without notice.

ELL COUPLING SIZE	CATALOG NO.	COPPER FLARE (BOTH ENDS)	LENGTH	HEIGHT	APPROX. WT. LBS.
3/4"	105NL-C3C3	3/4"	1.78"	1.78"	
1"	105NL-C4C4	1"			
1 1/2"	105NL-C6C6	1 1/2"	2.95"	2.95"	
2"	105NL-C7C7	2"	3.44"	3.44"	

Submitted by: